



SKYRAY

SIGCL23



ASSEMBLY AND OPERATING INSTRUCTIONS

PARTS INVENTORY

We understand how anxious you are to get started building and flying your SKYRAY, but before you do, please take a few minutes to inventory the contents of this package. Inside the box you should find:

- | | |
|---|--|
| <ul style="list-style-type: none">• One-Piece Sheet Balsa Wing• Die-Cut Balsa Profile Fuselage• Die-Cut Sheet Balsa Tail Surfaces• Die-Cut Plywood Parts• Formed Wire Pushrod | <ul style="list-style-type: none">• Nylon Bellcrank• Nylon Control Horn• Decals• Hardware Pack• Illustrated Instructions |
|---|--|

If you are missing any of these items, call SIG to obtain the missing parts.

TOOLS NEEDED

In addition to the items provided, you will need the following tools to assemble and fly this model:

1	Modeling Knife or Single-Edge Razor Blade
1	Sheet of 200-300 grit Sandpaper
1	Small Screwdriver
1	Small Brush (1" camel hair brush recommended)
2	"D" Cell Alkaline Batteries

BUILDING THE SKYRAY KIT

The SIG SKYRAY kit contains its own detailed instruction sheet. The front of the instruction sheet pertains to building the model. The back of the sheet has a PRE-FLIGHT CHECKLIST and CONTROL-LINE BASICS section with lots of helpful tips for newcomers.

Complete all the construction steps 1 through 22 to build your SKYRAY. Work slowly and follow the building instructions exactly. In order for your SKYRAY to fly as well as was designed to, it must be properly assembled. A model airplane that is not built properly will not fly properly! We can provide you with a proven design, quality materials, and detailed instructions, but ultimately the flight characteristics of your finished model depends on how well you put it all together.

BUILDING NOTE #1:

Step 18 of the kit building instructions say to paint the model with color dope after the initial coats of clear dope.

This is optional.

The SKYRAY will fly the same with a clear dope finish or with a color dope finish. If you decide you want a color finish on your model, you will need to buy some color dope from your local hobby shop, or direct from SIG. Be sure to use only SIG SUPERCOAT COLOR DOPE - others paints are not compatible with the clear dope that is already on the model.

BUILDING NOTE #2:

Look at the side view drawing of the SKYRAY near the bottom left corner of the kit building instruction sheet. Notice back by the tail that it says;

"CONTROL HORN: USE MIDDLE HOLE FOR STUNTING. USE BOTTOM HOLE FOR TRAINING."

If you have never flown a control-line model airplane before, we strongly recommend that you install the pushrod in the bottom hole of the control horn.

MOUNT PROPELLER ON ENGINE

Install the SPRING STARTER and the molded plastic SNAP STARTER CAM onto the front of the engine's crankshaft.

Install the PROPELLER on the engine shaft with the PROP SCREW. Flat side of propeller blades should face engine.

Tighten prop screw securely.

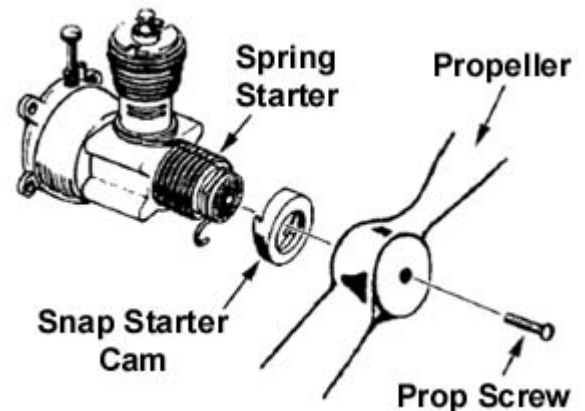

CONTROL HANDLE ASSEMBLY

- Cut the small plastic CLAMP WASHER from the molded CONTROL HANDLE. Insert the #2 x 1/4" METAL SCREW through the clamp washer and thread it into the middle hole of the control handle. Do not overtighten!

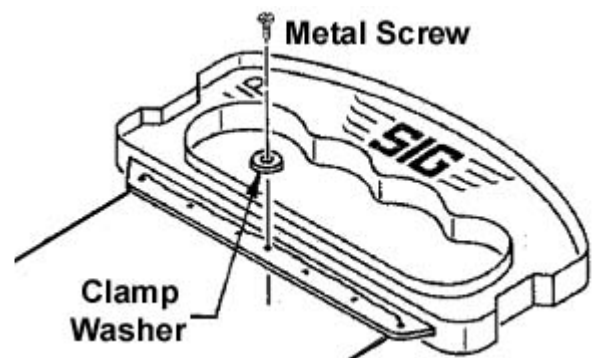

- b. Thread one end of the DACRON LINE through the top and bottom holes in the control handle as shown. Continue pulling the line through until both lines coming from the handle are the same length.

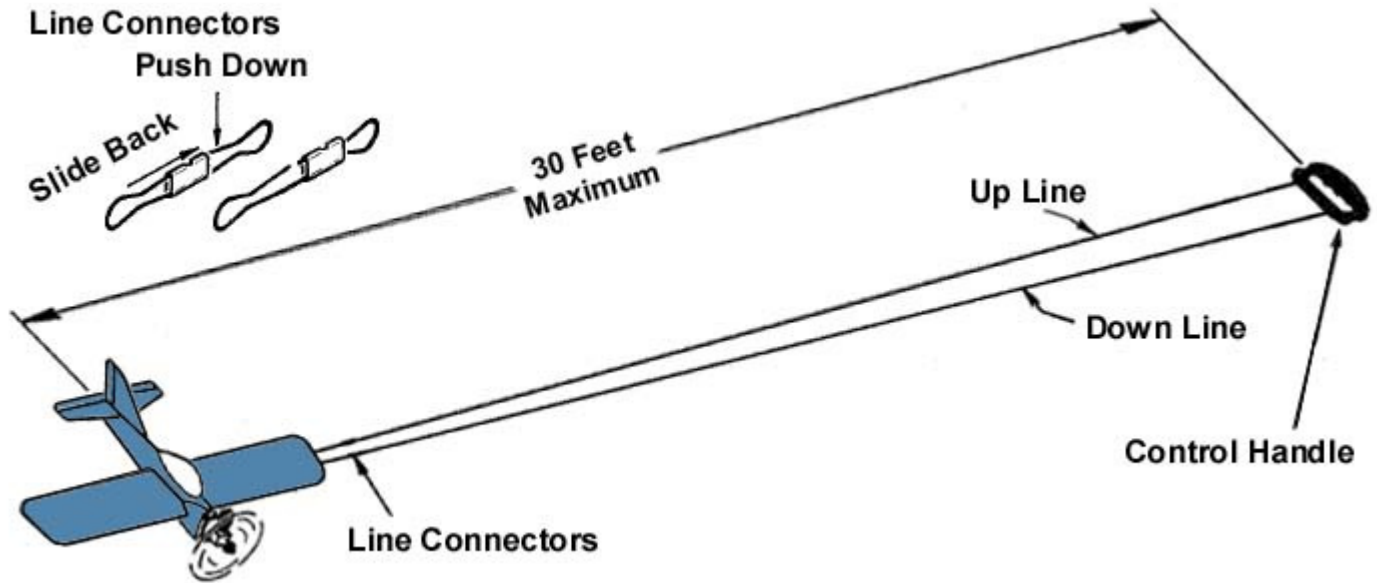

- c. Tie the ends of the control lines securely to the LINE CONNECTORS and cut off any excess line. The final distance between the center-line of the model and the center-line of the control handle should be 27-30 feet.
- d. Fasten the line connectors to the model's leadouts. Make sure the up line from the handle connects to the up leadout, and the down line connects to the down leadout.

ADJUST THE CONTROL HANDLE TO NEUTRAL POSITION

Have a helper hold the model at shoulder height as in level flight. Hold the handle in neutral position (straight up and down) while pulling tight on the lines. When the handle is in the neutral position, the elevator should be level. If not, loosen the clamp washer and lengthen the line that is too short (this will shorten the line that is too long at the same time). Re-tighten the clamp and recheck for neutral position. It will probably take several small re-adjustments to get the neutral set exactly level.

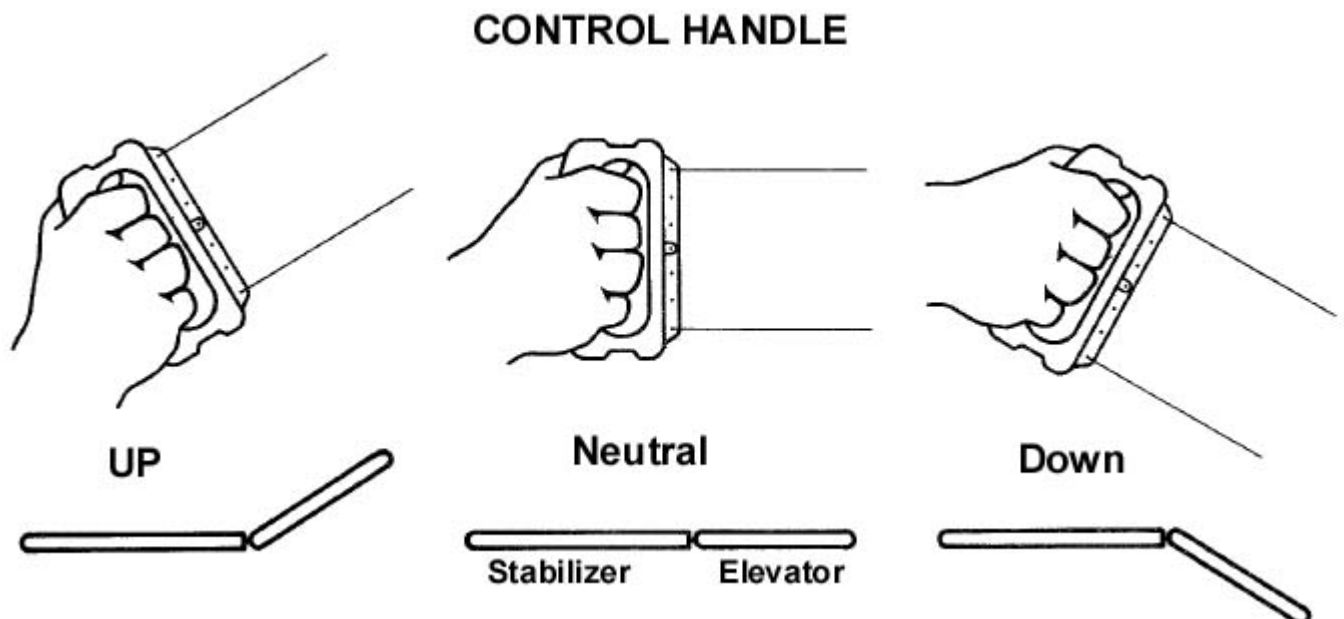

CONTROL HANDLE SENSITIVITY ADJUSTMENT

Three sets of holes are molded into the handle to allow changing the CONTROL HANDLE SENSITIVITY. Moving the control lines closer together at the handle will lessen the amount of elevator travel for the same amount of handle movement. Moving the lines further apart will increase the elevator travel.

- X** Changing this distance at the control handle will change the ratio of handle movement to elevator movement.
- A** Best for most sport models.
- B** Less sensitive than A. Recommended for learning to fly, or for very fast models.
- C** Least Sensitive. Seldom used.

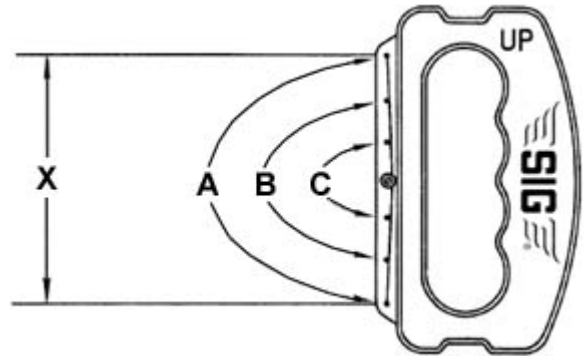

LINE STORAGE

Always store the control lines on the handle between flying sessions. Roll the lines on/off the handle by rotating the handle as you walk towards/away from the model.

To unroll the lines for flying, first connect the lines to the model and then walk away from it, rotating the handle as you go.

To roll up the lines after flying, leave them attached to the model while you walk towards the model, rotating the handle as you go.

Do not wind the lines onto the handle by hand - this will twist and tangle the lines making them difficult to unroll and use again.



STARTING BATTERY

Assemble the BATTERY CASE according to the separate instructions provided.

FUELER

A 1/2 oz. plastic (syringe-type) FUELER and a piece of BLACK RUBBER FUEL TUBING is provided for putting fuel in the fuel tank. Slip the tubing onto the front of the FUELER and it is ready to use.



STARTING THE ENGINE

- a. Close the needle valve (turn clockwise). Do not force or over tighten the needle valve. After closing, open needle valve (turn counter clockwise) 3 turns.
- b. Fill the fuel tank. Fuel will flow out the overflow on top of the tank when tank is full. Wipe any excess fuel from the engine and tank.
- c. Prime the engine. Close the exhaust ports by rotating the propeller until the piston blocks the ports. Squirt several drops of fuel into the exhaust ports. Flip the propeller over 3-4 times to work the fuel into the engine.

- d. Connect the glow plug clip to the glow head of the engine. The bottom of the clip should rest on top of the glow head.
- e. Start the engine. Wind the propeller backwards (clockwise) until the spring hook catches on the notch in the snap starter cam. After the cam is engaged, wind the propeller backwards one full turn. (To prevent damage to the starter spring, never wind propeller more than one full turn.) Release the propeller - the engine should start.
- If after a few attempts, the engine does not start, open the needle valve another 1/2 turn (counter clockwise), reprime, and repeat starting procedure. If engine still won't start, refer to the engine trouble-shooting section.
- f. Once the engine is running, slowly screw in the needle valve (turn clockwise) until the engine is running at top speed. At top speed, the engine should produce a shrill whine. After engine has reached top speed, slowly screw out the needle valve approximately 1/2 turn, or until engine runs with a "crackling" or "bubbling" sound. Remove the glow plug clip and let the engine run until the fuel tank runs dry and the engine quits. Restart and repeat the procedure until the engine has burned a minimum of 3 tanks of fuel.
- NOTE: Be sure to hold the airplane level whenever you are adjusting the needle valve, otherwise you will be getting a false reading of the engine speed.
- g. Refuel and restart the engine. Turn in the needle valve until the engine is running at top speed. Remove the glow plug clip. If the engine holds top RPM without slowing down, it is properly broken in.
- h. With engine running at top speed, tip the nose of the airplane up to a 45 degree angle. If the engine speed changes, readjust the needle valve by turning it out a little.

ENGINE TROUBLESHOOTING CHART		
WHAT YOU SEE AND HEAR	WHAT TO LOOK FOR	WHAT YOU SHOULD DO
WILL NOT START. ACTS LIKE THE BATTERY ISN'T ATTACHED TO THE GLOW HEAD.	Poor battery connection	Check connections of wires to battery and check to be sure clip is firmly and correctly attached to the glow head.
	Weak or dead battery.	A good battery should test 1-1/2 volts. Connect battery to a good glow head. If glow head coil does not glow bright, replace battery.
	Burned out glow head.	Remove glow head. Attach glow head to a good 1-1/2 volt battery. If glow head filament does not glow bright orange, replace glow head.
	Glow head loose.	Tighten glow head with wrench.
	Engine wasn't primed.	Squirt a few drops of fuel through exhaust ports and onto side of piston, then continue with starting procedure.
	Dirt under reed valve.	Remove tank. Wash reed and retainer in clean fuel or rubbing alcohol.
	Engine flooded. Too much fuel in cylinder. Makes a sizzling sound.	Close needle valve 1 full turn and start again (without priming). 4 or 5 starts may be required to clear engine.
ENGINE POPS OR "KICKS" - WON'T START.	Loose propeller screw.	Tighten propeller screw.
	Dirt under reed valve.	Remove tank. Wash reed and retainer in clean fuel or rubbing alcohol.
ENGINE STIFF. PROPELLER TURNS HARD OR "KICKS".	Engine flooded. Too much fuel in cylinder. Makes a sizzling sound.	Close needle valve completely. Leave battery attached and flip propeller (without priming) until short starting "burst" occurs. Then open needle valve 3-1/2 turns and start again.
ENGINE STARTS, THEN SLOWS DOWN AND STOPS.	Excess fuel at ports. Mixture is too rich.	Close needle valve. Flip propeller until engine starts and burns out excess fuel. Open needle valve and restart.
SHORT RUNNING "BURST" (BRIEF START, THEN STOP).	Engine not getting enough fuel. Fuel tank is empty or mixture is too lean.	Check fuel in tank - refill if necessary. Or, open needle valve another 1/2 turn, prime and start again. It may be necessary to repeat this procedure 3 or 4 times, opening the needle valve 1/2 turn each time.
ROUGH RUNNING ENGINE - SLUGGISH WEAK POWER.	Loose glow head.	Tighten glow head with wrench.
	Engine set too rich or too lean.	Re-adjust needle valve.

CHANGING ENGINE GLOW HEAD

Eventually the glow head of your engine is going to burn out and will have to be replaced. You can purchase a new glow head at your local hobby shop, or direct from SIG. Use both wrenches to remove the old glow head. The top fin on the engine cylinder has two flats. Insert one wrench over these flats and hold in place while using the other wrench to remove the glow head. When installing the new glow head, make sure it is tight! An engine with a loose glow head will not run.

ENGINE STORAGE

Before storing, run engine until fuel tank is dry. Lubricant in model fuel thickens upon prolonged exposure to air and will clog parts if allowed to remain in the tank. Oil engine with light oil such as SAE10, 3-In-One oil, or sewing machine oil. Then wrap in plastic bag or clean cloth to protect it from dust and dirt.

CAUTION:

Use only top quality glow fuel (such as the SIG fuel provided).
NEVER USE GASOLINE IN THIS ENGINE!
Gasoline can explode and burn, causing serious injury to you and others. Glow fuel can also burn you if not used with caution. Glow fuel burns with an almost invisible flame. Use common sense, be careful, and follow these rules:

- Never fuel or prime engine with the battery connected to the engine.
- Wipe excess fuel from engine and model with cloth after each fueling or priming.
- Do not operate engine indoors.
- Do not smoke when fueling or operating engine.

ENGINE WARRANTY

Your COX engine is fully warranted against factory defects for 90 days from the date of purchase. Glow heads are NOT WARRANTED since they normally require periodic replacement. Should your engine require warranty service, contact COX Customer Service at: 800-451-0339.

DANGER

DO NOT FLY NEAR ELECTRIC POWER LINES!
Instant death can result from contact with, or flying too close to, electric power lines.

WARNING!
THIS IS NOT A TOY

Flying machines of any form, either model-size or full-size, are not toys! Because of the speeds that airplanes must achieve in order to fly, they are capable of causing serious bodily injury and property damage if they crash. IT IS YOUR RESPONSIBILITY AND YOURS ALONE to assemble this model airplane correctly according to the instructions, to inspect and ground test the finished model before each flight to make sure it is airworthy, and to always fly your model in a safe location and in a safe manner.

GOOD LUCK AND FLY SAFELY!

© Copyright SIG Mfg. Co., Inc.

SIG MFG. CO., INC.....Montezuma, Iowa 50171-0520

LIMIT OF LIABILITY:

In use of our products, Sig Mfg. Co.'s only obligation shall be to replace such quantity of the product proven to be defective. User shall determine the suitability of the product for his or her intended use and shall assume all risk and liability in connection therewith.