

# ZLIN AKROBAT

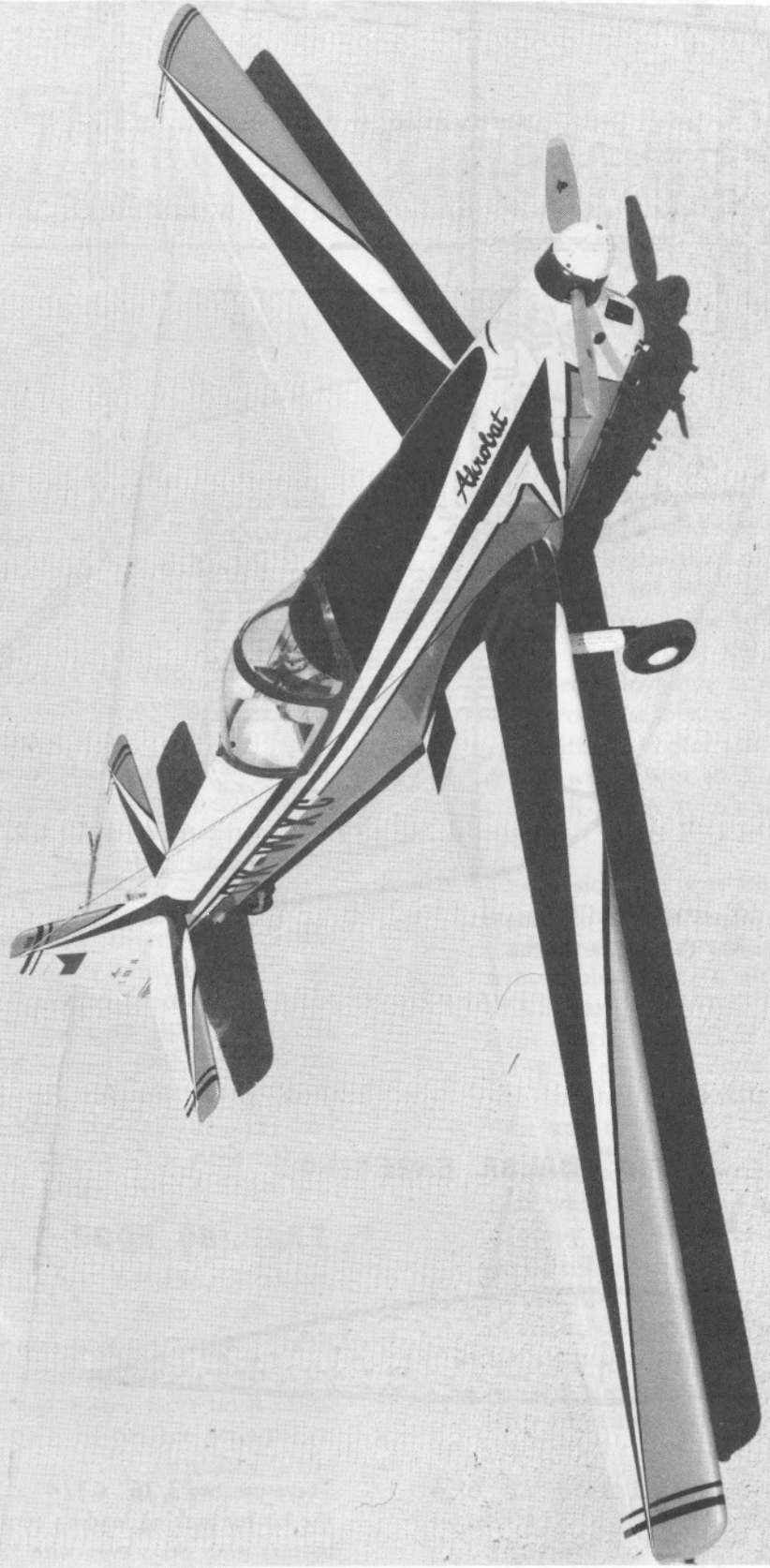

**SIG MANUFACTURING CO., INC.**

DA 73

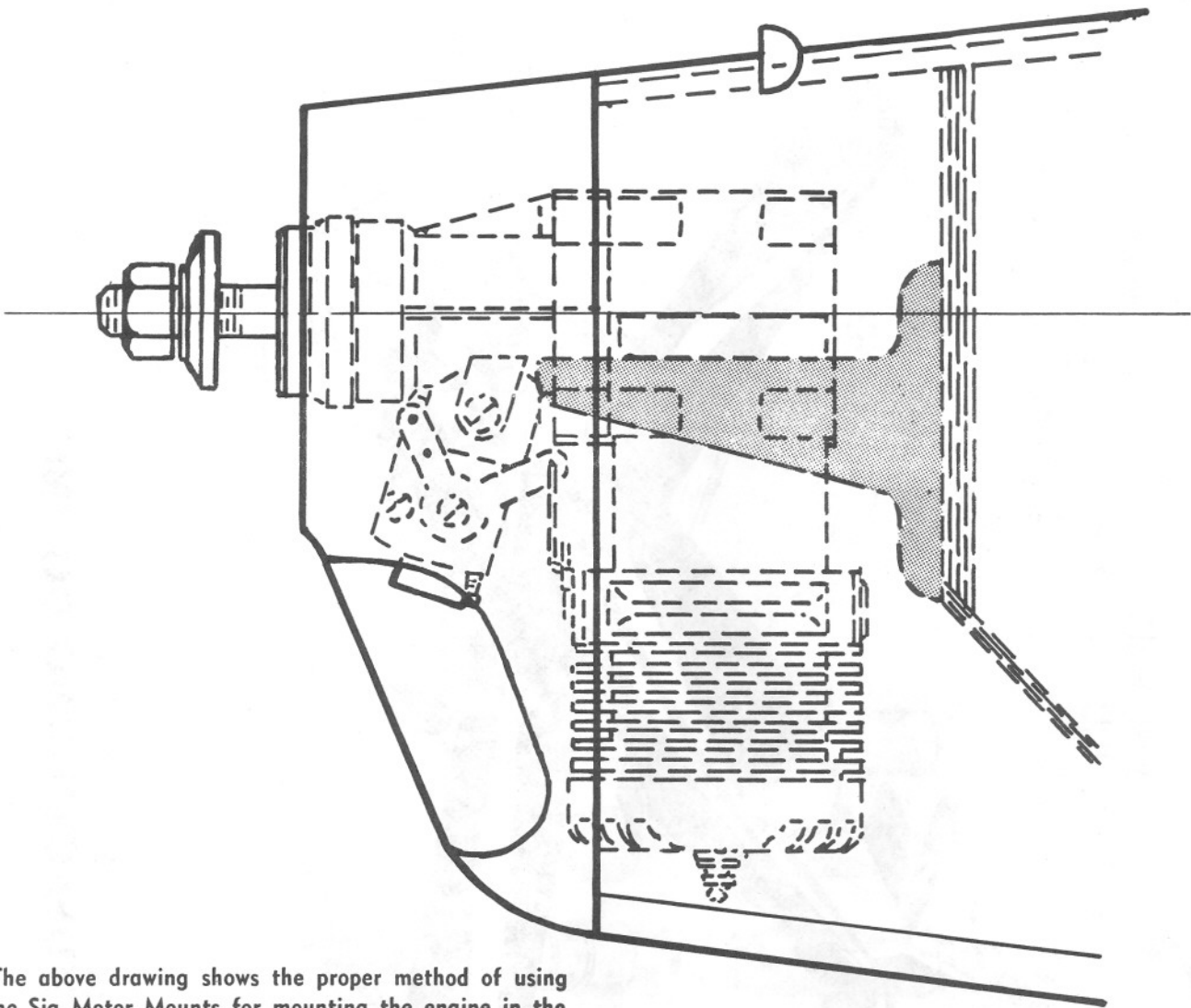

The above drawing shows the proper method of using the Sig Motor Mounts for mounting the engine in the Zlin.

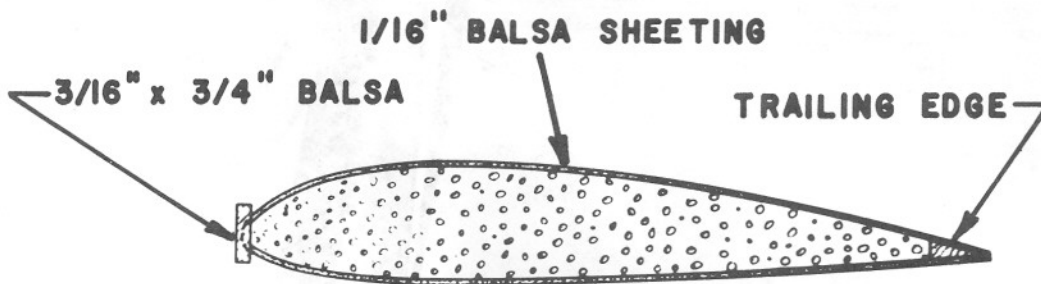

The plastic parts now furnished in the Zlin kit can be cemented with Sigment instead of a special kind of cement.

There are two  $3/16" \times 3/4" \times 36"$  sticks furnished with the kit for making leading edges. Apply the top and bottom wing skins even with the foam core. Sand the leading edge square by using a sanding block. Glue the  $3/16" \times 3/4"$  leading edge piece in place with Sig-Bond. When dry, carve and sand to shape.

# Instructions For Building the Zlin Akrobat

**by Maxey Hester**

The Zlin Akrobat is the ideal R-C scale model. It is true scale, 2" equals one foot and easy to build. The resulting configuration is such that the model flies well enough for a full pattern airplane.

When I first saw pictures of the Zlin I felt sure that it would make an excellent flying model and still be absolutely accurate scale. The first test flight proved this theory as its flight characteristics were even better than I had hoped. After the initial flight of WXD I was so impressed by its performance that I started the second Zlin, WXC, that very evening.

When first looking over the three-views, I was concerned about the narrow landing gear and expected difficulty in ground handling. After the very first take-off I could see that there was not going to be any problems. Only a slight bit of right rudder is held on take-off. Touch-and-goes and full stop landings are straight away and I have never had a ground loop with either plane. The main reason for building two airplanes was that I wanted to fly in the '69 Nationals and I was already on the U. S. R-C Scale Team to compete in the world championships at Bremen, Germany, the week following the Nats. Also, with two planes I could get in more practice before both events without fear of washing out my only scale entry. As it all ended up, I still have both Zlins, OK-WXD and OK-WXC, in perfect condition. The only difference in the two airplanes is the basic color, WXD being light green and WXC is light blue. The extra practice paid off with first place at the '69 Nationals.

Frequently it is very difficult to find adequate three-views and sufficient scale information on an airplane to be a truly accurate scale model and

have ample proof for scale judging. Claude McCullough obtained the three-views from a modeler in Czechoslovakia, plus several black and white photos, but no color photos. Hale Wallace happened to have some color slides of the Z 526 AS. There were five of the 526AS planes built for the Czechoslovakian team to compete in the full-scale world aerobatic championships. They were all a different color and the letters started with A and went through E. Factory numbers started with OK-WXA 1026 and went through OK-WXE 1030.

The basic color was white, with red and black trim. The bottom half of the fuselage, most of the bottom of the wing and the wing tip was a different color on each airplane. WXA was a gray, WXB was gold, WXC was light blue, WXD was light green and WXE was orange-yellow. The complex paint schemes were a little difficult to mask off but the results were well worth the extra time and trouble.

I first sprayed the entire airplane with Sig Supercoat white, then masked off with tape and paper to spray the base color of blue or green. I then taped off for the black and red and brushed these colors on. I always spray on three or four coats of reduced clear over the color and rub with rubbing compound. I then put the final lustre on by using a sheepskin pad in a quarter-inch electric drill and fine rubbing compound.

As I stated before, the ground-handling is excellent. In all of the flights I have made with the two Zlins I have never had a ground loop on take-off or landing. The main reason for this good handling is that the center-of-gravity is well forward. I placed the battery pack above the tank, then the servo. I used a C.I. model for the

with his body cut off just below the arms, replacing it with styrofoam in the body and foam rubber strips in the legs, with his shoes fastened to his pants legs

I used the M-K retract gears from Royal, reworking them so they would retract straight back. A fifth channel with a separate model servo was used to switch the M-K retract servo. I used four pen cells on the retract servo.

The center of gravity was not changed after all of the equipment was placed in the plane. Both models came out at the same weight and the same balance point. The Zlin can be built lighter than either of mine, as I use a lot of dope (I get it cheap). Both of mine weighed 8-1/4 pounds.

I did not realize what I had gotten myself into by building two scale model airplanes until it came to putting on the detail. I test flew the first model about six or seven weeks before the Nationals with no detail at all. I was really pushed for time and didn't get all of the detail finished, and that is what beat me at the world championships. The Zlin received the highest flying scores at both the Nationals and the World Championships, but in FAI competition, detail points count a great deal. I chose the radio equipment and engines that I used because of past experience and the trust I had

in them. I had been using Logictrol for two years and knew I could trust my two new Zlins to Logictrol Radio. I have also used Enya engines for many years without trouble. I do not believe in changing unless something is definitely proven better.

I drew the plans for the Zlin and built and test flew the WXD. Then the second model, the WXC was built without any changes being made.

I first built a foam wing, then decided I might save some weight by selecting all very light wood for a built up wing. As it turned out, I spent much more time on the built-up wings and did not gain any advantage in weight. The foam wing weighed only one ounce more than the wing of balsa ribs and spar construction.

The plans show a fixed landing gear, with a sketch on how to modify the MK Retract Gear. I would not recommend the retract gear on anything but a smooth field.

The engine fits in the cowling very closely, but by using a K-O muffler you are able to get the exhaust out of the cowling. The engine cools well and I had no over-heating problems. The air comes in the front air intakes and goes out the bottom of the nose at the leading edge of the

I did not find any of the control surfaces critical or real sensitive on the stick. The rudder is large and only a little right is needed on take-off. After a flight or two, you will find the right amount to apply.

If your experience is limited in flying a scale model, have an experienced multi pilot assist you on the first flights, until you can handle the plane easily by yourself. The Zlin is no harder to fly than the average Class III airplane.

A word of warning on flying a scale model airplane: Always have plenty of flying speed before trying to take the airplane off the ground. Never try to "horse it off" as you are really asking for trouble. On landing, maintain sufficient air speed to avoid stalling, keeping the nose slightly down until ready to flair out for touch down. The Zlin will roll on the main wheels after touching down and the tail wheel can be brought down after it has lost forward speed by gently applying up elevator, but only after the plane is well below flying speed.



## WING CONSTRUCTION

The foam wing core comes with the dihedral angle already cut, and also cut-outs for the aileron bellcranks and landing gear blocks. Epoxy the balsa landing gear back up blocks in first, then the hard wood block to plug the landing gear into. Now epoxy the grooved wood block in place. Hold these blocks to the forward side of the cut-out, leaving room for the plywood dihedral splice which will be installed after the wing skin has been applied.

Install the aileron bellcrank to  $1\frac{1}{8}$  x  $1\frac{3}{4}$  x  $1\frac{3}{4}$  plywood and epoxy into the cut-outs in the foam wing core. Glue the  $1\frac{1}{4}$  x  $\frac{3}{4}$  trailing edge piece to the trailing edge of the wing core. Sig Bond is very good to use here. Do not use model cement, as it will dissolve the foam.

Make the cut-out for the aileron servo to accept your own particular servo. Leave room to line the opening of the cut-out in the foam with scrap balsa sheet. The pushrods for the ailerons can be installed after sheeting the wing.

## RETRACTABLE LANDING GEAR

If retractable gear is used, make the proper installation now before covering the wing core. The M-K gear will require a plywood mounting and some others will require beam mounts. A razor saw blade can be used to make the proper cut-out. The cut-out in the wing core for the non-retract gear can be filled with a block of balsa. Do not cut the opening for the gear larger than necessary as it will weaken the wing. If too much is cut away the wing should be strengthened with a plywood splice

The  $1\frac{1}{16}$ " x 6" wing covering may be applied to the foam core one sheet at a time or glue four of them together and then apply the sheeting in one piece. If the latter is used, make a paper pattern of the wing core by wrapping a large sheet of paper around the core and cutting to shape, leaving a little extra at the edges which can be trimmed away later. Lay the pattern on the  $1\frac{1}{16}$ " x

24" x 36" sheets that you have glued up and cut to size.

Core Bond is the best cement I have found to cement the wing covering to the foam core. Coat the wing covering and the foam core with Core Bond, using a stiff bristle brush. Let the Core Bond dry completely before applying the sheeting to the foam core, usually about forty-five minutes to one hour. Lay the sheet on a flat surface with glue side up and place the trailing edge of the foam core at the edge of the wing sheeting and roll the core toward the leading edge. Before bending the sheet around the leading edge, remove from the table and wet the sheet with a sponge where the sheet will bend around the leading edge of the foam core. Now place the wing back on the table with the skin side down and press down, rolling the skin around the leading edge and on to the trailing edge. Repeat the procedure with the other wing half.

Before applying the tip blocks, cut out the ailerons. Measure from the wing tip  $17\frac{5}{16}$ " at the trailing edge towards the center of the wing. Use a square and draw a line towards the leading edge  $2\frac{3}{4}$ ". Measure from the trailing edge at the tip towards the leading edge  $1\frac{7}{8}$ ". Use a ball point pen to draw a line from the  $1\frac{7}{8}$ " mark to the  $2\frac{3}{4}$ " mark. Use a razor saw and cut along this line all the way through the wing. After the aileron has been cut from the wing, cut the leading edge of the aileron to  $1\frac{1}{4}$ " at the tip, to 2" at the inboard end of the aileron.

Shape the  $\frac{3}{4}$ " x  $1\frac{1}{8}$ " balsa piece (note section CC on wing plan). Use Sig Bond or Sig Epoxy to glue in place. Repeat the process for the  $1\frac{1}{2}$ " x  $\frac{7}{8}$ " leading edge of the aileron. Glue sheet balsa scrap  $\frac{3}{32}$ " thick to each of the ailerons and to the wing at the inboard end of the ailerons, covering the foam completely so that no dope can get to the foam core.

Use the vinyl strip and make up the aileron hinges, making four sets. The aileron hinge pins can be removed by making a small notch in the bottom side of the aileron. Epoxy the hinges into the ailerons first and then into the wing. Glue the wing tip blocks to each wing tip and shape to conform with the wing and ailerons.

Make the aileron horns from a piece of the vinyl  $1\frac{1}{8}$ " long. Drill a  $\frac{1}{16}$ " hole in one end for the push rod and a series of holes in the other end. Make a small groove in the aileron and work epoxy into the holes and groove in the ailerons. See section CC of the wing plans.

Use a pin to locate the aileron bellcrank where the push rods from the servo and bellcrank meet.

aileron horn will fasten. Cut a hole at each location about 5|8" diameter and install the push-rods. The holes will be covered later with the silk covering.

Before epoxying the plywood dihedral splice, check to see that it fits in place. Epoxy the joiners into one side of the wing. Apply epoxy to the center end of the wing and to the splice joiner and fit the two wing halves together. Before the epoxy sets up, check the wing to be certain there is no twist in it. This is extremely important. Hold the joint together with masking tape until the epoxy has dried.

At the center leading edge of the wing there is a flat place on the foam core. Sand the edges of the wing covering even with the foam core (using a sanding block) and cap with a piece of 3|16" sheet balsa. Use a sanding block to smooth out

### FUSELAGE CONSTRUCTION

Lay wax paper over the side of the plans that shows the fuselage side view. A piece of Celotex about 12" wide and 48" long, laid on a flat table makes an excellent building surface for the fuselage sides. The Celotex is easy to pin into and also holds the pins well.

Cut 5|16" square stock to length shown and pin in place over the side view of the plans. Glue in place the die-cut 1|8" fuselage sides above the wing, glueing two together to form a 1|4" thick side. Glue in the upright pieces and the diagonal braces of 5|16" square. When dry, remove from plan and make another side the same way, but shim up under the two 1|8" fuselage sides above the wing. This will give you a right and left fuselage side with the fuselage side pieces flush with the outside edge of the 5|16" square.

Lay the wax paper over the top view of the fuselage plan and pin the fuselage side frames to the plan upside down at F4 and F5. Cut 5|16" to length and cement in place at F4 and F5. Make two each of the 5|16" cross pieces and cement them in place working from F4 forward. Hold the sides together with rubber bands. Now work from F5 back to the tail, glueing the 5|16" cross pieces in

While this stage is drying, epoxy the two 1|8" plywood F-11 firewall pieces together. Locate the position of the motor mounts, drill holes and install the 6-32 blind nuts in F-1. The width of the holes will depend on the engine you use. The height can be located from the thrust line. Epoxy F-1 to the fuselage frame and the 1|4" balsa sheet to the bottom of the 5|16" square under the tank compartment. Now epoxy the 1|8" plywood that

runs from the bottom of F-1 to the 1|4" sheet. Check the plan at the F-1 location. Drill holes in F-1 for the tank fuel lines. Epoxy in place the wing hold down blocks in the fuselage. The leading edge block is a solid block that goes across the fuselage. Two separate blocks are used at the trailing edge of the wing. A piece of scrap plywood can be epoxyed to the fuse sides at the trailing edge if desired before the trailing edge wing hold-down blocks are installed (I did not use the plywood on the sides).

Lay the wing on the fuselage and mark the location of the 1|8" plywood tongue that goes in the wing. Remove the wing from the fuselage and saw or cut a groove in the leading edge wide enough for the plywood. Use plenty of epoxy in the slot and install the plywood tongue. Lay the wing on the fuselage in correct position (use wax paper between the block and the plywood) and leave in place until the epoxy sets. While the wing is still on the fuselage, drill and tap the 1|4-20 holes for the nylon wing bolts (use a 13|64 drill bit).

The fuselage top formers are now ready to install. Let the cement on these dry before adding the 1|4" stringers. The bottom 1|8" x 3|8" stringer can now be cemented to the bottom of the fuselage and then shaped. The side stringers, 1|8" x 5|16" and lower stringer 1|8" x 1|8" are shaped after being cemented in place. Check the side view plan for location and top view plan for taper. They can also be checked at different cross sections (section BB, F6 and F9). The lines running on the outside of the stringers represent the silk covering and not a side former. Also there is a 1|8" strip cemented to the fuselage sides above the wing, following the curve of the wing cut-out. By now the top formers should be dry and you can cement the 1|4" square top stringers.

Shape the top stringers with a sanding block so that there are no sharp edges or bumps protruding. Before sheeting the top of the fuselage, epoxy the half-inch nose block to each side of the nose section. Apply the fuselage top 1|8" sheeting in sections as shown, splicing it at the center of the top of the fuselage. The sheeting between F-3 and F-4 is spliced on the side of the fuselage on the 5|16" square that runs at an angle from F-3 to F-4 and then the 1|8" sheet at an angle to the leading edge of the wing opening. There is another 1|16" sheet laminated to the 1|8" sheet on the top of the nose section forward of F-1 to the cowl and back to F-3. Let the blocks on the sides and the top sheeting of the nose section protrude farther than the plan shows which can be shaped down later when fitting the engine cowling. F-

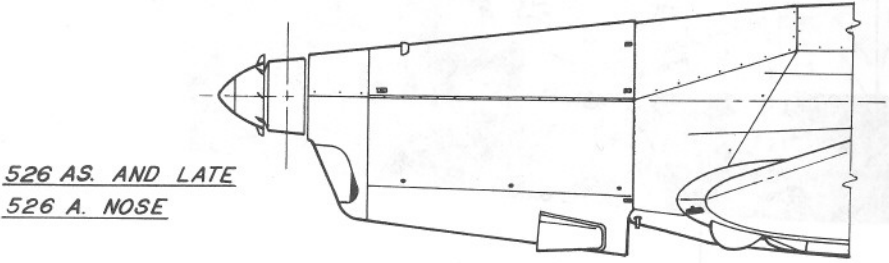
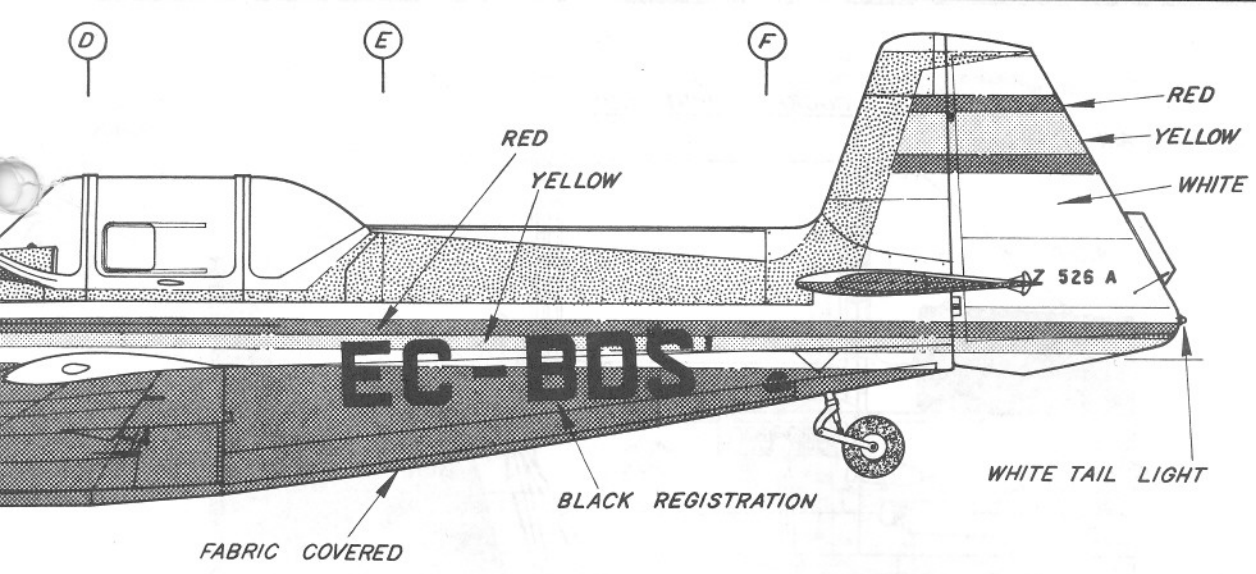

526 AS. AND LATE  
526 A. NOSE

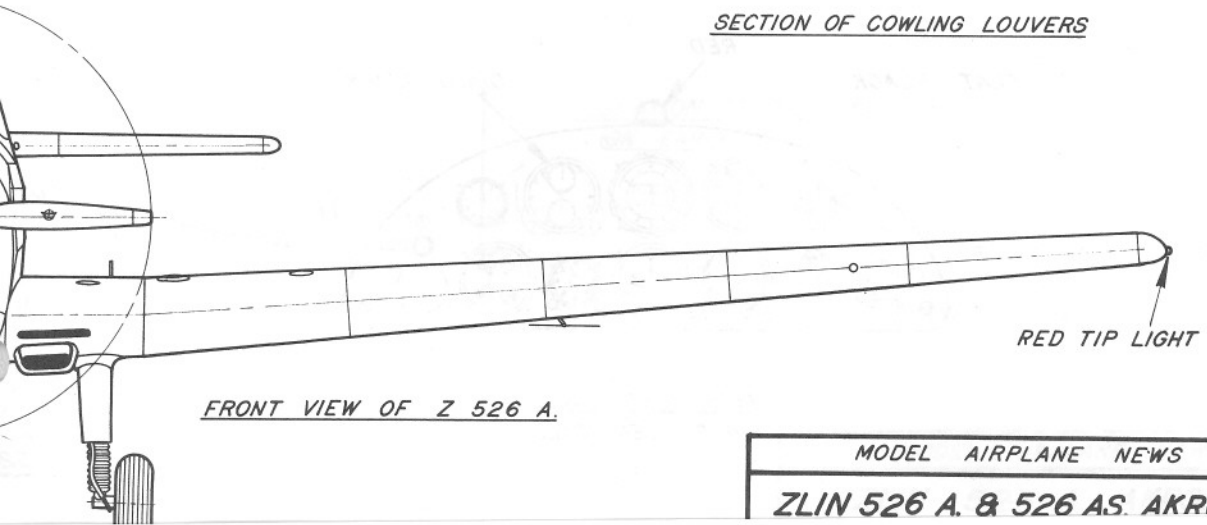
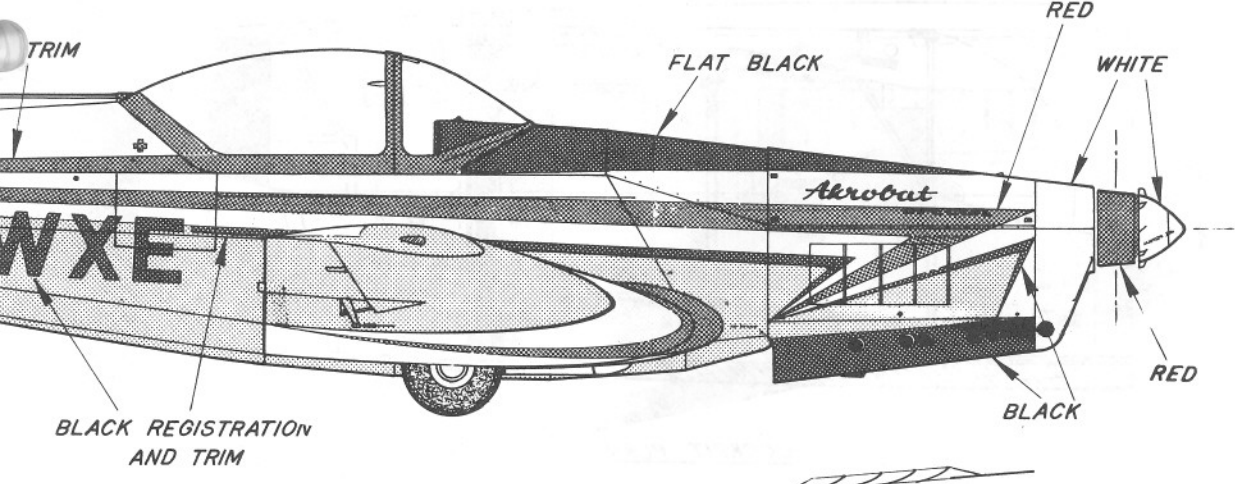

COCKPIT RIGHT SIDE

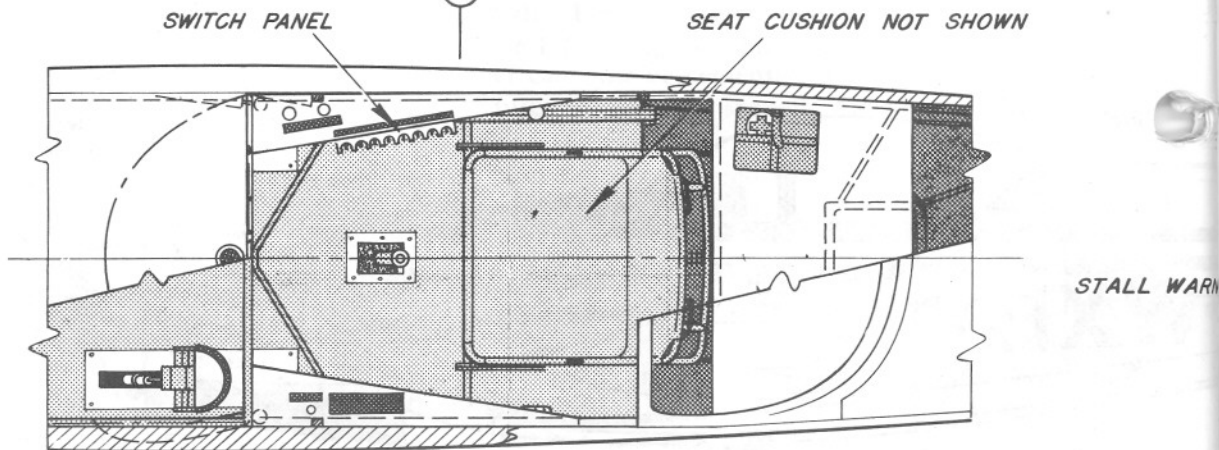
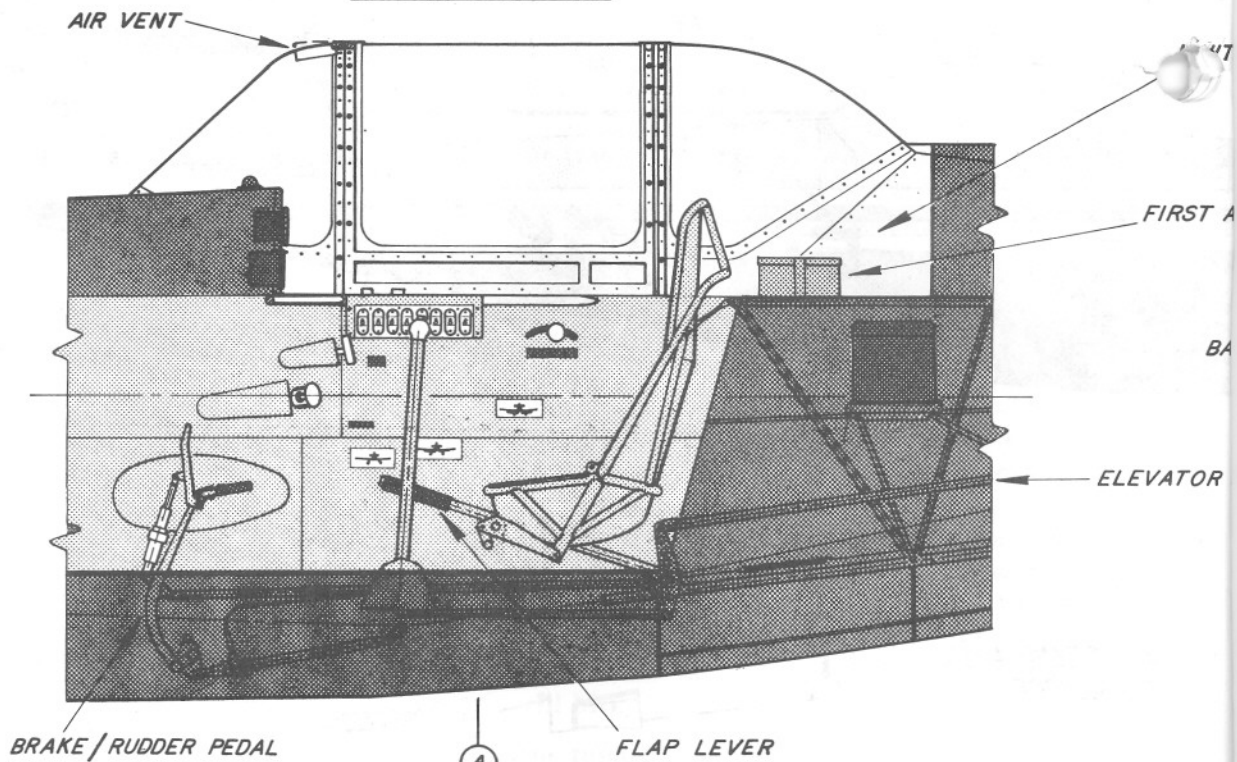

COCKPIT PLAN

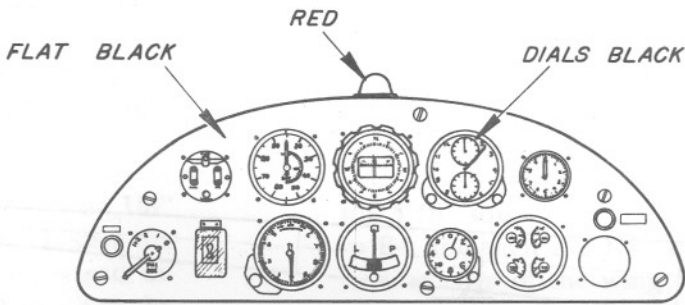

INSTRUMENT PANEL  
TWICE GIVEN SCALE

SECTION 'A' FOR

MID GREY



SCALE IN FEET

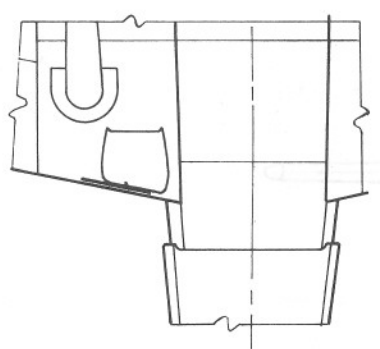
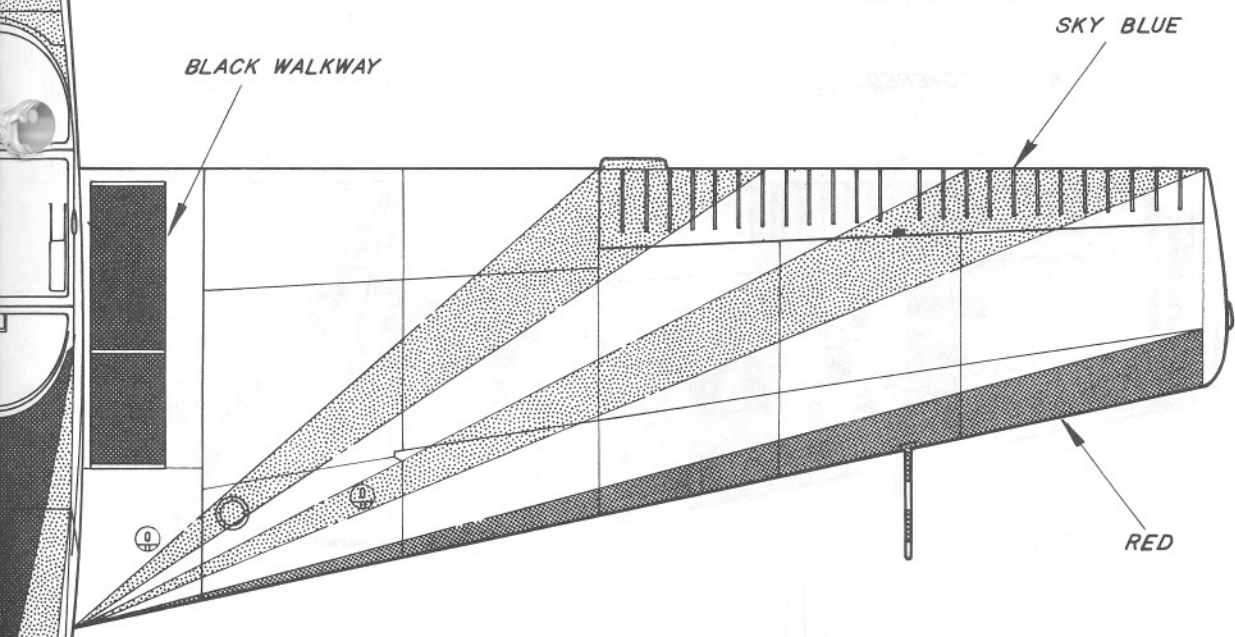
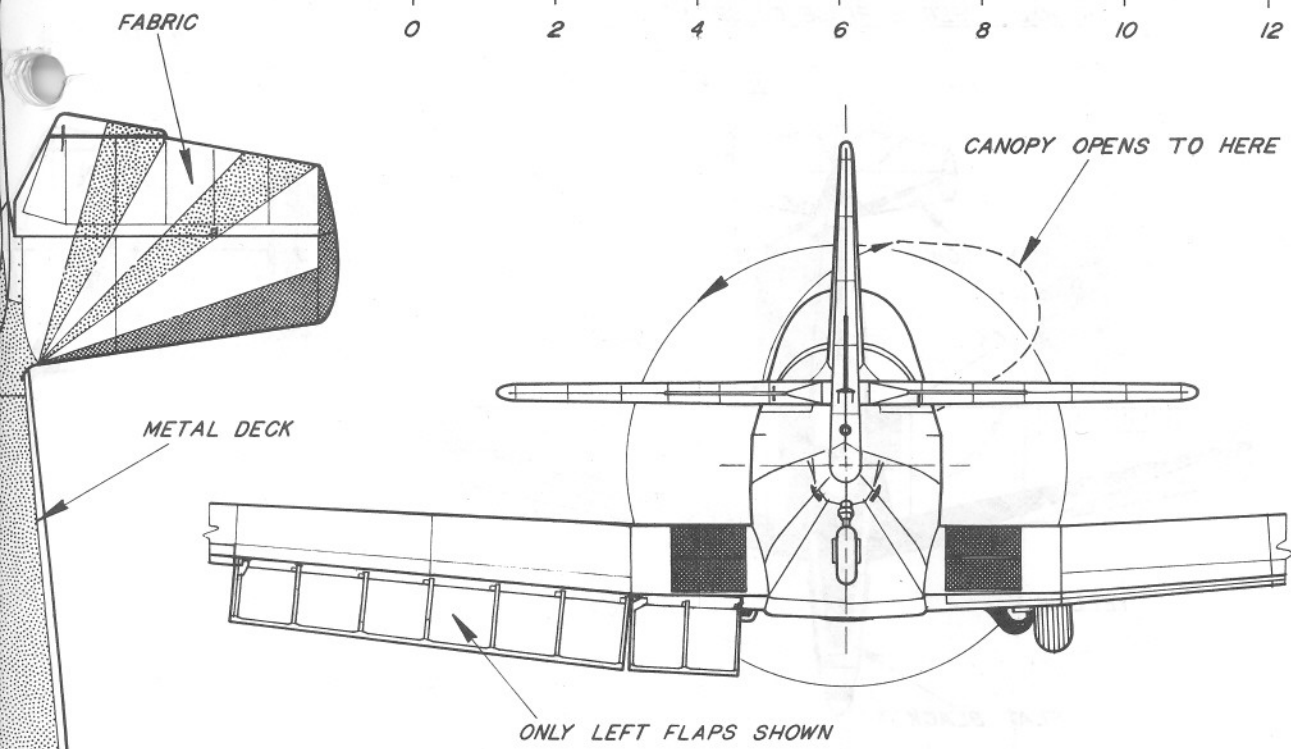
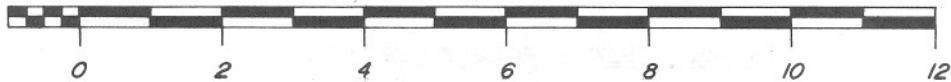

LOCATION OF OIL COOLER  
ON EARLY Z 526 A.

THE ZLIN 526 AKROBAT IS CURRENTLY  
CONSIDERED THE TOP COMPETITION  
AEROBATIC PLANE IN THE WORLD.

RED

OK-WXE UPPER SURFACE COLOR SCHEME

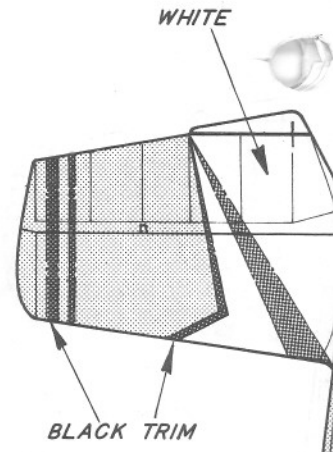
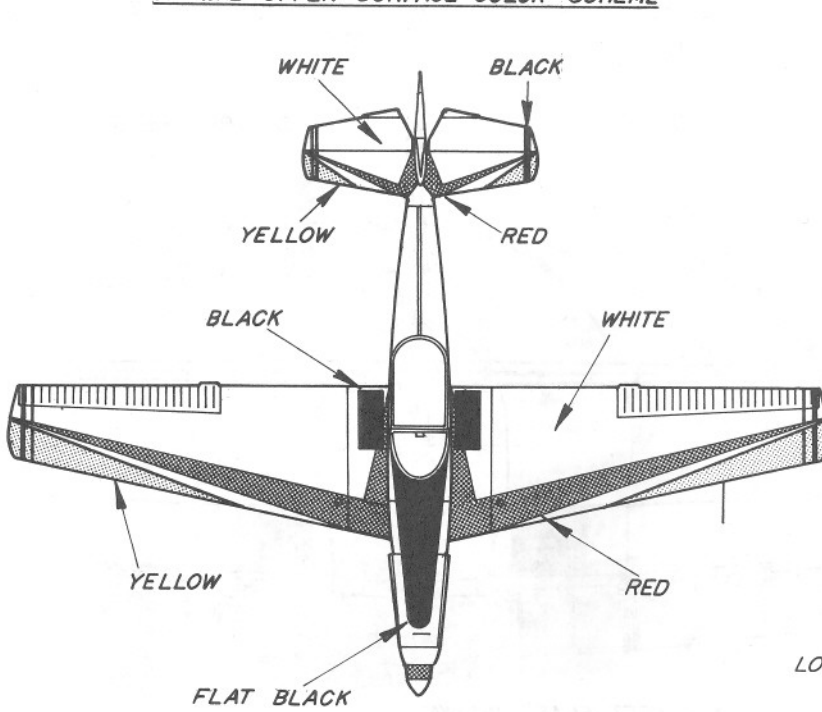

LOCATION OF FLAPS ON Z 526 A.  
NOT FITTED TO Z 526 AS.

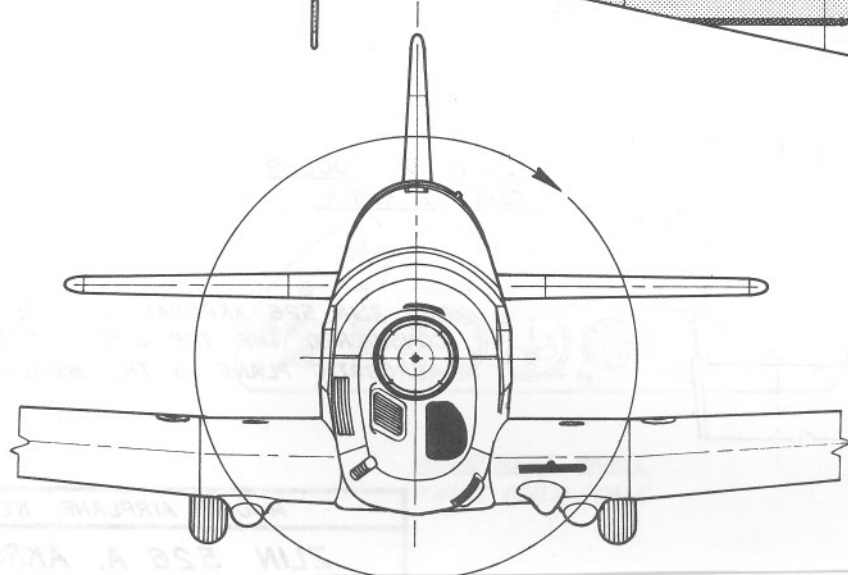
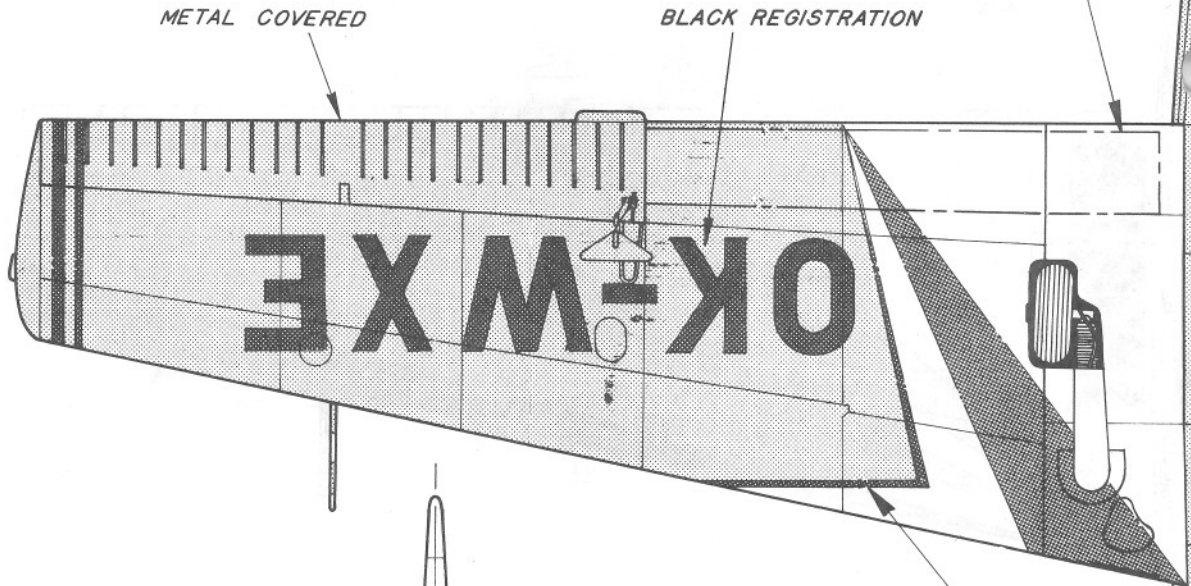

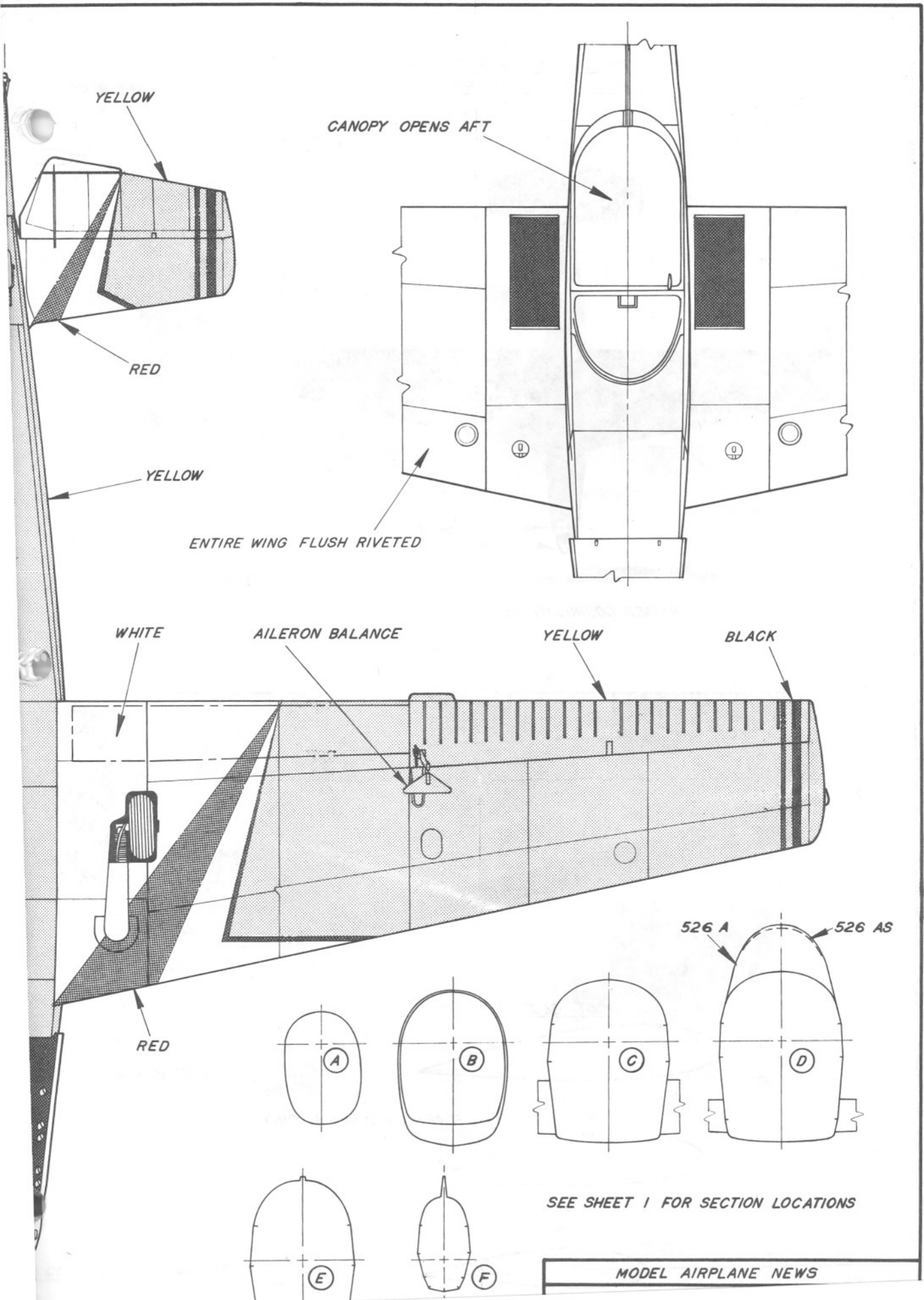

COLOR SCHEME ON THIS PLAN  
SHEET IS FOR EC-BDS

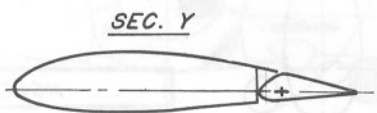
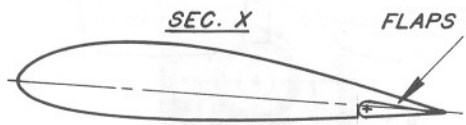
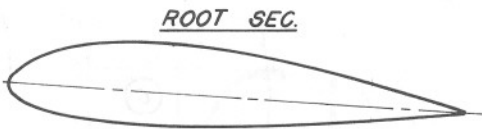
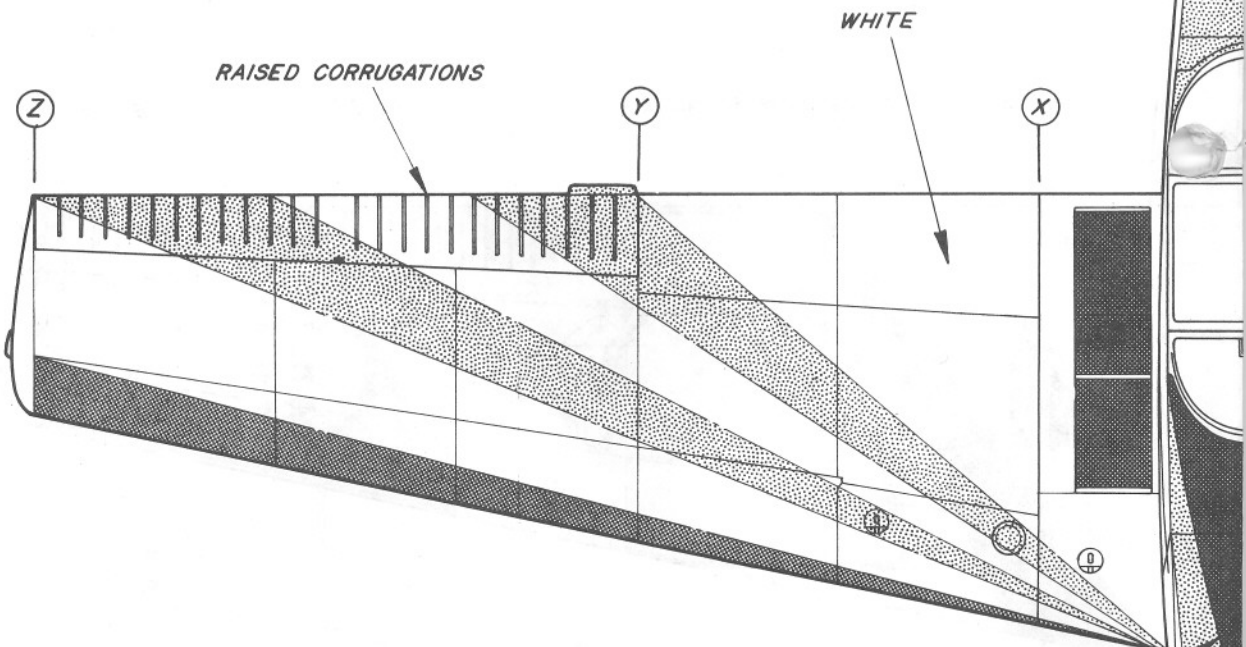
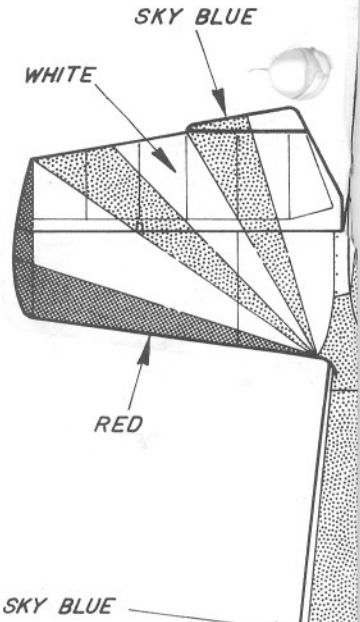
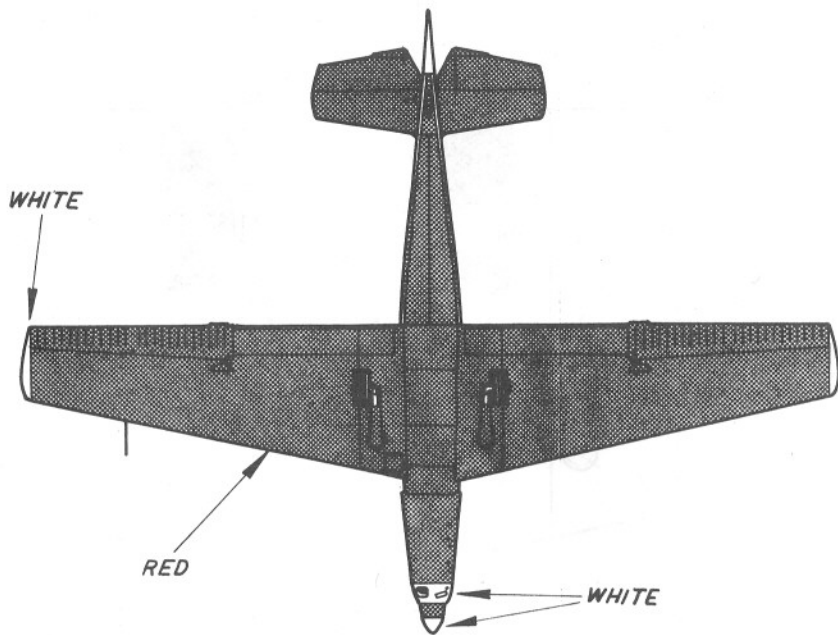

FLAT BLACK



COCKPIT LEFT SIDE

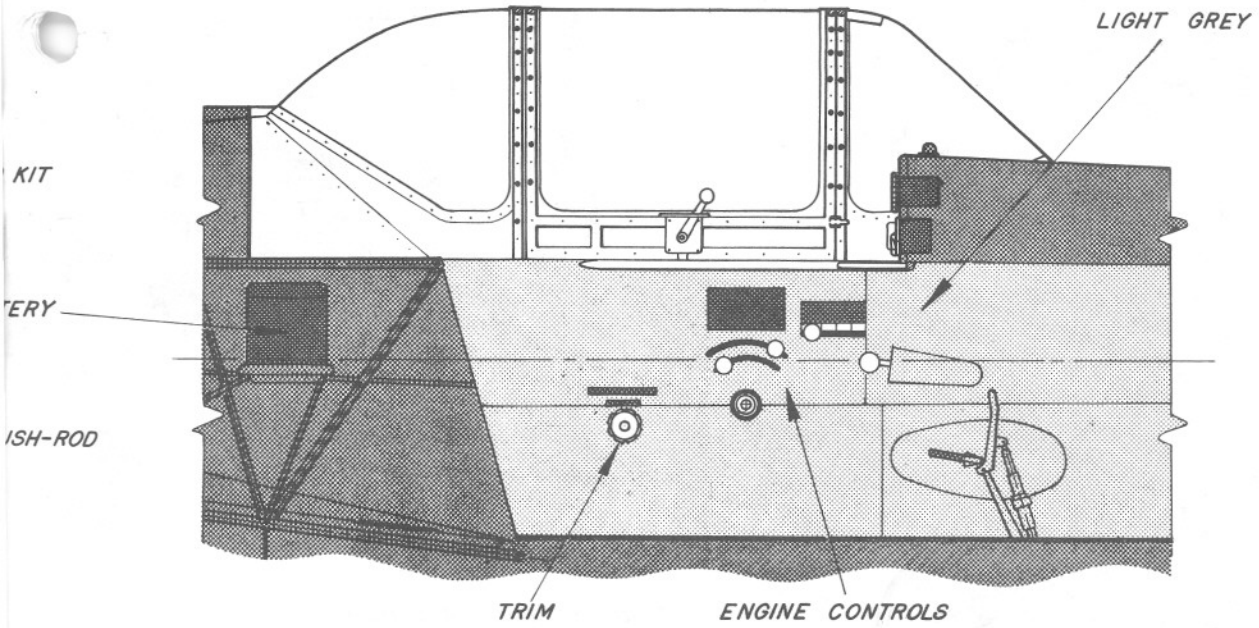

SCALE IN FEET

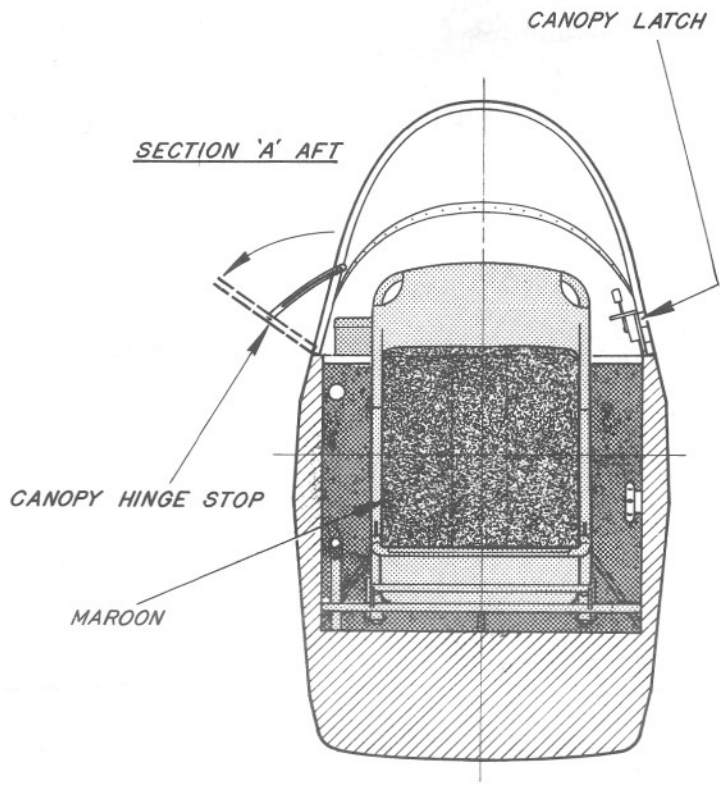
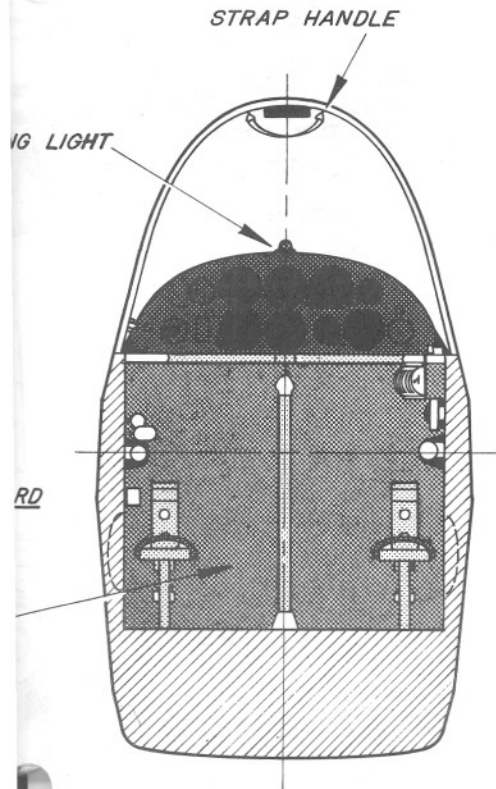

COCKPIT LAYOUT SIMILAR

MODEL AIRPLANE NEWS

71 IN 526 A - AKORAT

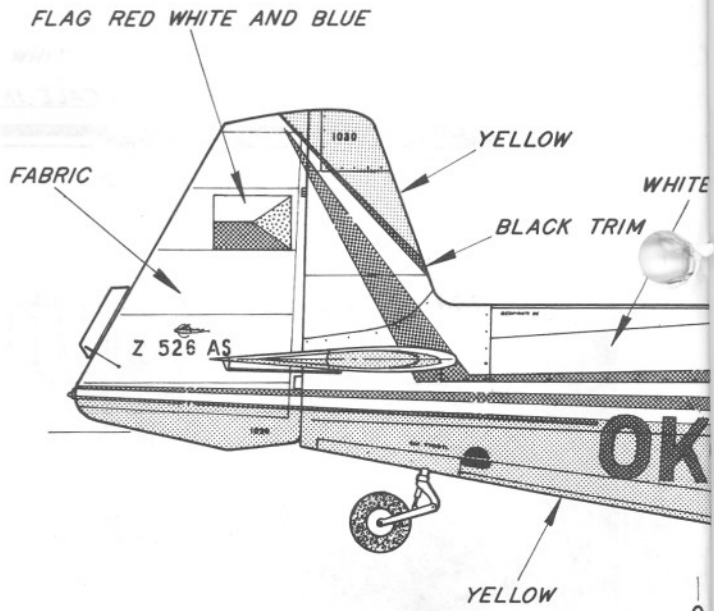
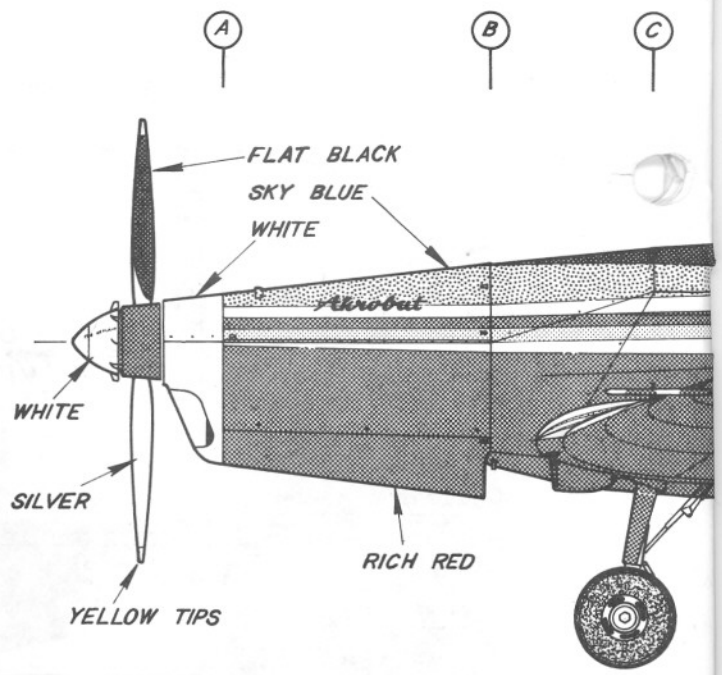
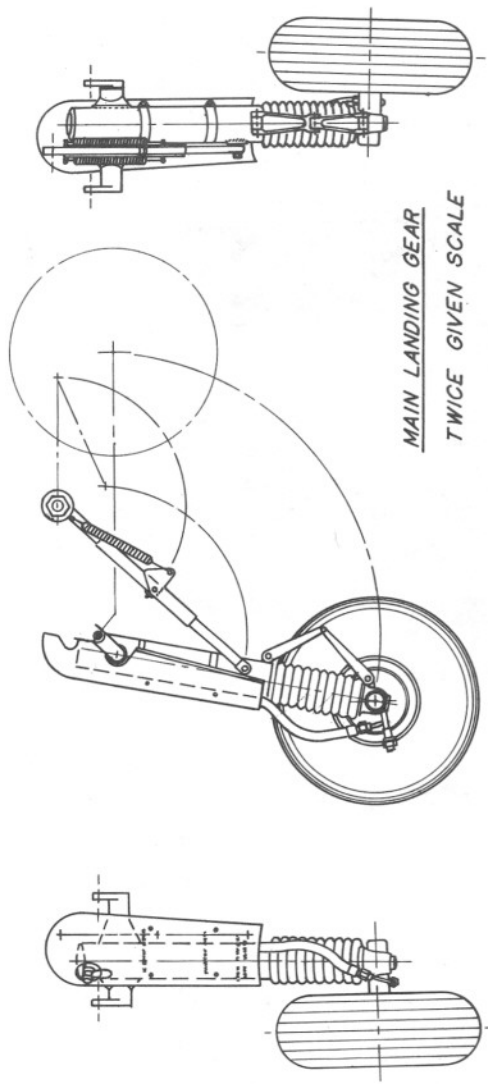

AUTHENTICATION  
THESE DRAWINGS WERE PREPARED FROM  
FACTORY DRAWINGS AND ADDITIONAL  
PHOTOGRAPHIC DATA.

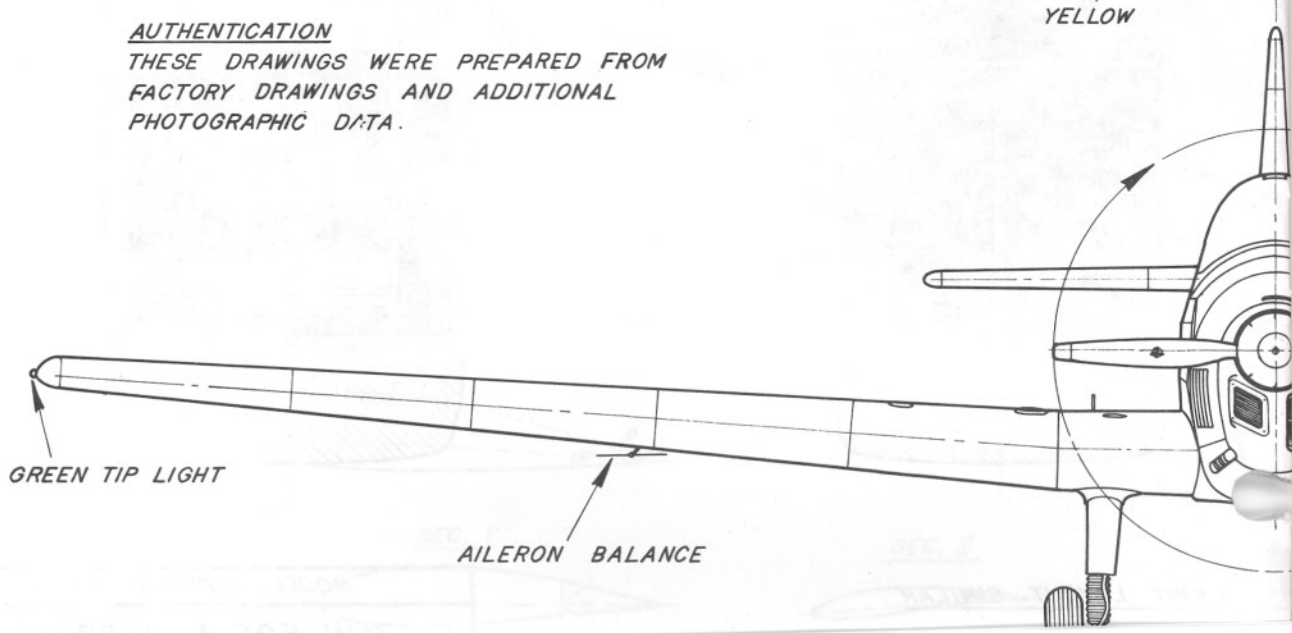

poxy the bottom pieces of the nose in place, 2-5|16" x 7|8" and the bottom piece is 5|16" x 2-1|2". Check F-1 section for cross view. This section is built hollow for engine cooling. The plywood ring at section A-A is installed only after the nose section has been sanded to fit the engine cowling.

The stab is cemented to a shaped block. Tack glue the balsa tail block in a couple of places to the 5|16" square fuselage frame. Shape the tail block to conform with the fuselage top. Then remove and cut out for the stab.

The tail wheel parts should be assembled and installed in the fuselage. Cement a scrap piece of 1|4" balsa between the 5|16" square fuselage frame from F-9 to the tail of the fuselage. This will serve to mount the tail wheel plywood too. See tail wheel assembly detail. Solder the tail wheel brass tubes together over the 3|32" music wire as shown. The bottom parts 1 through 5 will turn and 6 and 7 will be soldered to the shim brass and epoxied to the plywood and to the 1|4" sheet in the bottom of the fuselage. Make two holes in this one for the push rod to the servo and one for the rod to the rudder horn.

### STABILIZER CONSTRUCTION

Build the stab over the plan by blocking up the 3|8" square leading edge and the 1|2" square trailing edge as needed. Cement the stabilizer ribs in place and shape the leading edge and the trailing edge with a sanding block to conform to the shape of the stab ribs. Cover the top and bottom of the stab with 1|16" sheet.

The elevators can also be constructed over the plan. The leading edge is 1|2" square. The trailing edge is made up of two different sizes of trailing edge stock, 3|16" x 3|8" and 5|16" x 1-1|4". Cut off the trim tabs after painting and then replace on the elevators. The elevators are not sheeted, only silk covered.

Join the two elevators together with a tail horn assembly such as the Top Flite or Veco horns. You can make your own, if desired, with a piece of 3|32" music wire and a metal horn. The holes for the push rod should be as shown on the plan.

### FIN AND RUDDER

The fin and rudder are built in the same manner as the stabilizer. The fin is covered with 1|16" sheet and the rudder is silk covered. The rudder horn is made from a 90 degree bellcrank. Saw a slot in the bottom of the rudder (see plan for location) and epoxy the bellcrank in place.

The rudder and elevator can be hinged after they are silked. Use pins that have been cut off or

round tooth picks. Epoxy the stab to the fuselage and check to make certain that the distance from the 5|16" square frame is the same at the leading edge as at the trailing edge. Add a small fillet block to the top of the stab. The fin will be epoxied to this fillet block. The fillet can be finished off with Sig Epoxolite. Add the 3|16" dorsal fin to the top of the fuselage.

Fasten the wing in place on the fuselage. Cement the two F-10 pieces to the bottom of the wing. Cement a balsa block between the F-10 pieces at the leading edge and trailing edge of the wing and sand to shape. Cover the bottom with 1|8" sheet and sand. Remove the wing from the fuselage and drill out the bolt holes.

The engine cowling will require a hole cut in the front part. Check the scale view for the location. Also cut out the back of the indented opening in the cowling. This can be done with a sharp knife. Epoxy four small blocks to the nose as shown on the plans and drill holes in them for screws to hold the engine cowling in place.

The nose section of the scale spinner is held in place with three screws. The fins on the spinner are made from .010" vinyl. Use a razor saw to saw the slots. The fins are cut over-size and shaped after installing. Bend the vinyl over about 1|4" and cement with vinyl cement on the inside of the spinner.

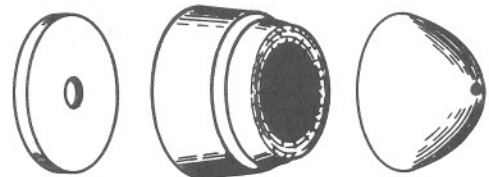

Before silking, carve out for the loovers in the right side of the fuselage nose section. Check plan for size and location. Make about 3|16" deep. Cut the loovers from vinyl and curve to the shape indicated, but do not install until the model is painted.

The exhaust stacks are made from 1|4" aluminum tubing epoxied in place as shown.

I used a K and O muffler to get the exhaust out of the engine compartment. If a muffler is not used then an exhaust stack should be made to get the exhaust outside to keep the engine from overheating. There is ample ventilation for the engine if the exhaust is run outside.

Landing gear covers are held in place by soldering a piece of shim brass or tin can stock to the landing gear. Drill holes in the tab ends and cement the vinyl covers to the tabs with vinyl cement. Use Epoxolite to fill each end of the shock covers and cement together with vinyl cement.

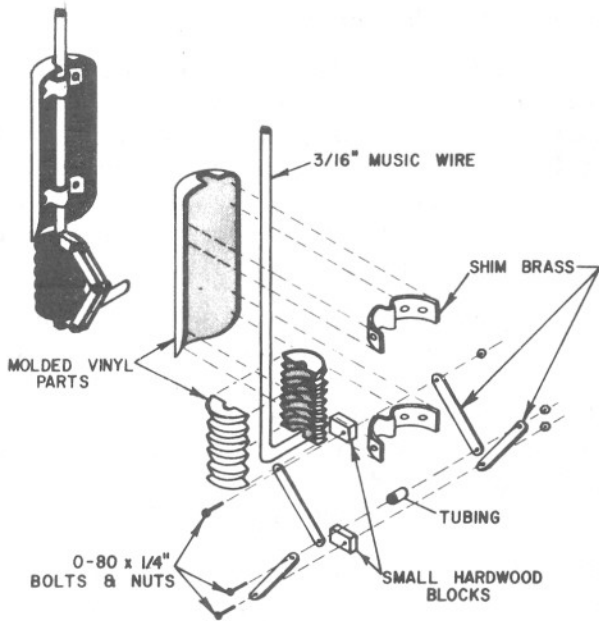

Trim the clear canopy to fit the fuselage. Use masking tape to outline the canopy frame on the white vinyl molded canopy. Cut out with X-Acto knife and sand the edges. Cement to the clear molded canopy. The canopy frame is painted red which can be done before the frame is cemented to the clear canopy and to the fuselage.

The scale prop is carved from balsa (See drawing for size and shape). Carve two separate blades and join together with brass tubing. Drill hole in tube to fit over crank shaft. The pitch of the blades should be set for clock-wise rotation. (See photo on wing plan sheet). Scale prop is for appearance and judging only, not for flight.

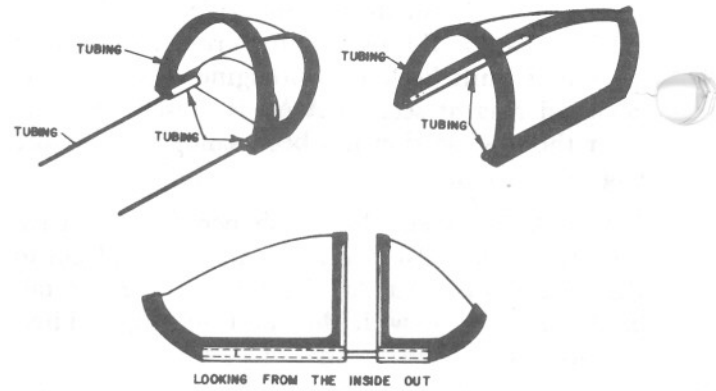

For those who would like a sliding canopy, first cut out the canopy frame and cement to the clear canopy. Use a razor saw to cut the front stationary part from the rear sliding portion (see plan for division point). The sliding parts were made from telescoping tubing, either plastic or brass. Tape the two portions of the canopy together with masking tape and locate the canopy on the fuselage. Cement the front portion to the fuselage and remove the rear, sliding part of the canopy.

Cut the tubing to be used to the length of the cockpit opening (both inside and outside tubes). Cut a piece of the outside tube the length of the front part of the canopy. Cement this piece over the end of the inside tube and cement to the inside of the front part of the canopy and up to the instrument panel. This will leave clearance for the rear large tube to slide without binding on the top edge of the cockpit opening.

The large rear tube is telescoped over the small tube and the canopy is taped in place on the fuselage. Cement the rear tube to the sliding portion of the canopy from the inside of the fuselage, through the wing opening.

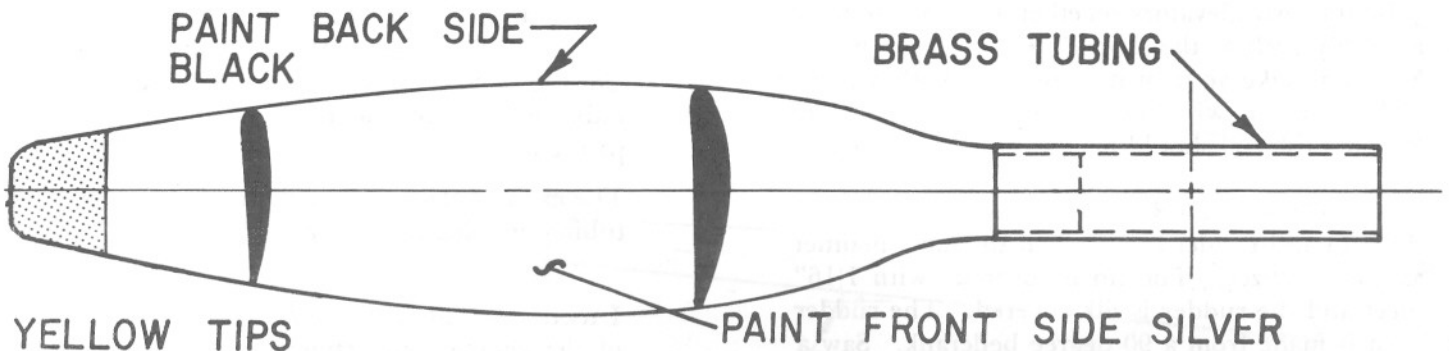

**CARVE SCALE PROP  
OUT OF BALS**



### SCALE DETAIL TIPS

The Zlin can receive more scale points than my airplanes did, with a little pains-taking work.

The V-shaped ribs for the ailerons can be cut from a V-channel used in model railroad work. These are about 1/16" which is very close to scale. The aileron ribbing should not be added until the ailerons are covered and painted except for the last coat. There should be no build-up of paint along the edges of the Vs as they will lose their shape.

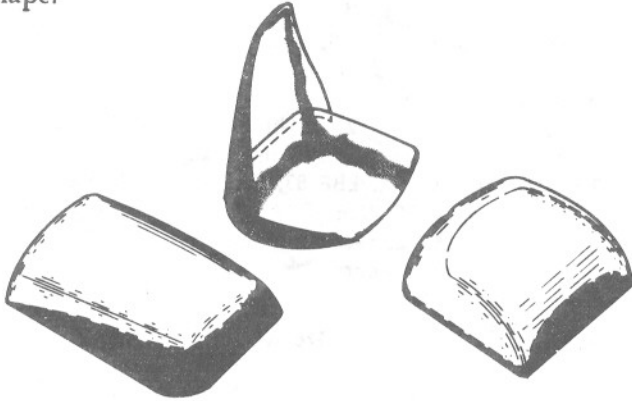

The small vinyl parts are not cut out. These can be cut with scissors or shears and then sanded to fit their proper location. They also may be cut out with a razor saw. The vinyl seat is cut to shape and cemented together with vinyl cement. The seat is secured to the bottom of the cockpit with two bolts.

For a more detailed metal skin effect, after the sanding sealer has been applied to the model, lay out the different metal panels according to the three-view. Score small, shallow lines in the sanding sealer with a sharp point such as a small piece of music wire ground to a fine point. You must be very careful not to fill these lines with paint. It may be necessary to go over the lines between coats.

The instrument panel is cut from vinyl. Lay out the instruments according to the pattern and drill holes the size of the instruments. Tatone instruments can be used.

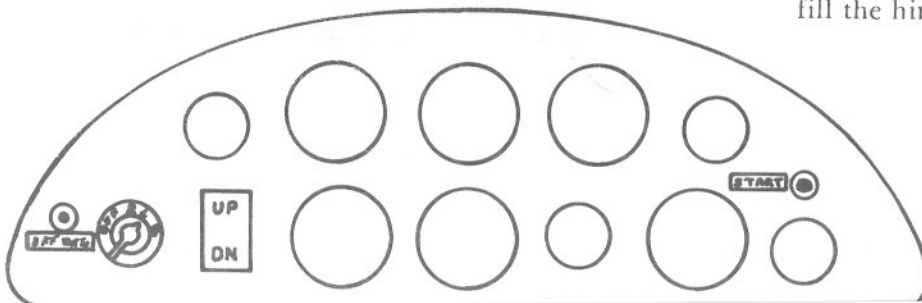

INSTRUMENT PANEL

### PAINTING AND FINISHING

Painting and finishing a model is very simple when done in the proper manner.

*First.* After all construction is completed, sand the entire surface. Fill any joints that might have open places with Sig Epoxolite. When sanding, use sanding blocks wherever possible. Don't try to hide defects with your finish. It just can't be done.

*Second.* Apply a coat of clear dope to all the wood surfaces and sand lightly. Follow this with a second coat of clear dope. Apply the silk in convenient panels, wet, smoothing out any wrinkles as it is applied. Adhere the silk with clear dope, brushing directly into the silk. Again pull out any wrinkles that might appear. Apply three coats of reduced dope to the silked model.

*Third.* Brush or spray on a good heavy coat of Supercoat Sanding Sealer and sand smooth. Be very careful not to sand into the silk. Be particularly careful around any projections or sharp corners as it is easier to sand through these areas. Follow with a second coat of sanding sealer and again sand the entire model until there is no rough spots, holes or low spots. Do all sanding with 3M 220 Tri-M-Ite Freecut Finishing Paper.

*Fourth.* Spray the entire model with Supercoat white. If you have created a good base with the sanding sealer, one or two coats of white will cover quite well. After the white is completely dry, mask off and spray the other main color coat. After the second color is dry, mask off and apply the red and black. These colors may be brushed on as the area is small.

The white vinyl engine cowling and engine parts were not painted. Cement the vinyl parts in place with vinyl cement only.

You will note on the three-views that the full-scale engine cowling uses a piano type hinge on each side and fasteners are used to hold the bottom section. The piano hinge can be simulated by making saw marks half way through a brass or aluminum tube with a razor saw. The tube can be imbedded in the nose section by means of a small groove in the balsa. Care should be taken not to fill the hinge with paint.

## SPECIFICATIONS AND PERFORMANCES OF Z 526 AIRCRAFT

The aircraft complies with the requirements of:

ICAO Annex 8 and Annex 6  
BVF requirements Category of use K 5  
BCAR Group D, Category Aerobatic and Special

### Dimensions

Span	10.596 m (35 ft) with auxiliary tanks (10.845 m or 35 ft 10 in)
Length	8.000 m (26 ft)
Height	2.060 m (6 ft 9 in)
Wing area	15.450 m <sup>2</sup> (166 sq. ft)

### Engine

Power	160 hp at 2500 r. p. m.
Number of cylinders	6
Cylinder volume	5.97 litres (366 cu. in)
Valves	push rod OHV
Maximum permissible engine r.p.m.	2750 r. p. m.
The engine is equipped with carburettor preheater.	
Specific fuel consumption	
cruising power	230 g/hp/hr + 10
rated power	245 g/hp/hr + 10
Ignition: SCINTILLA VERTEX	OBF 6 R 501 Z 170 OBF 6 R 701 Z 170
Starter: Walter P 320 with motor SCINTILLA MU 002 R	
Generator: 600 W, 24 V, LUN 2111 (52-9082.11)	

### Weights

	Category	
	aerobatic	normal (with auxiliary tanks)
<b>Z 526 A</b>		
Empty weight	640 kg (1411 lbs)	659 kg (1453 lbs)
Gross weight	850 kg (1874 lbs)	910 kg (2006 lbs)
Useful load	210 kg (463 lbs)	251 kg (553 lbs)

### Z 526

Empty weight	665 kg (1466 lbs)	674 kg (1486 lbs)
Gross weight	940 kg (2072 lbs)	975 kg (2150 lbs)
Useful load	275 kg (606 lbs)	301 kg (664 lbs)
Engine weight	126.8 kg (278 lbs)	
Propeller weight		
V 503	27.6 kg (61 lbs)	
Propeller diameter	1900 mm (7451/64 in)	
Range of propeller blade pitch automatic setting	10°	

### Fuel tank capacity

Main tanks	2×35 litres (2×7.7 Imp. gal.)	2×45 litres (2×9.9 Imp. gal.)
Reserve fuel tank	7 litres (1.5 Imp. gal.)	7 litres (1.5 Imp. gal.)
Connecting tanks	3.0 litres (0.66 gal.)	3.0 litres (0.66 gal.)
Auxiliary wingtip tanks	2×35 litres (2×7.7 Imp. gal.)	2×35 litres (2×7.7 Imp. gal.)
Type of fuel:	LBE 72, LBE 83, SHELL AVIATION GASOLINE GRADE 80/87 or equivalents	
Type of oil:	MS 20, AERO SHELL 120, ESSO 120 and equivalents	

Range	Z 526 A	Z 526
with auxiliary tanks	850 km (528 mi.)	930 km (578 mi.)
without auxiliary tanks	450 km (280 mi.)	530 km (330 mi.)
Flight endurance with auxiliary tanks	4.0 hours	4.5 hours
<b>Speeds (IAS)</b>	<b>Z 526 A</b>	<b>Z 526</b>
Cruising speed	208 km/h (129 mi.p.h.)	205 km/h (127 mi.p.h.)
Maximum speed	240 km/h (149 mi.p.h.)	238 km/h (148 mi.p.h.)
Maximum permissible speed		
according BCAR	292 km/h (181 mi.p.h.)	292 km/h (191 mi.p.h.)
according BVF	320 km/h (199 mi.p.h.)	320 km/h (199 mi.p.h.)
Minimum stalling speed with fully pulled elevator	120 km/h (75 mi.p.h.)	113 km/h (70 mi.p.h.)
Minimum stalling speed with fully pulled elevator, flaps down at 45 degrees, undercarriage down	100 km/h (62 mi.p.h.)	110 km/h (68 mi.p.h.)
Rate of climb	6 m/s (19.7 ft.p.s.)	5 m/s 16.4 ft.p.s.
Service ceiling	6000 m (19700 ft)	5000 m (16400 ft)
Climb to 1000 m (1100 yd)	3' 20"	3' 40"

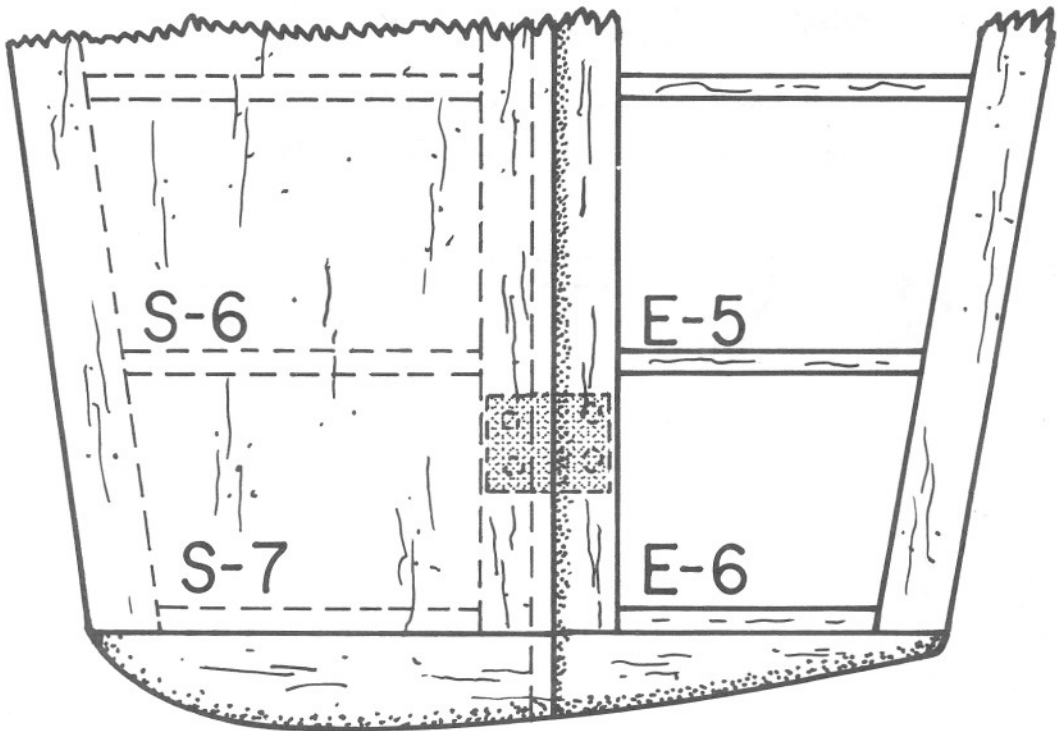
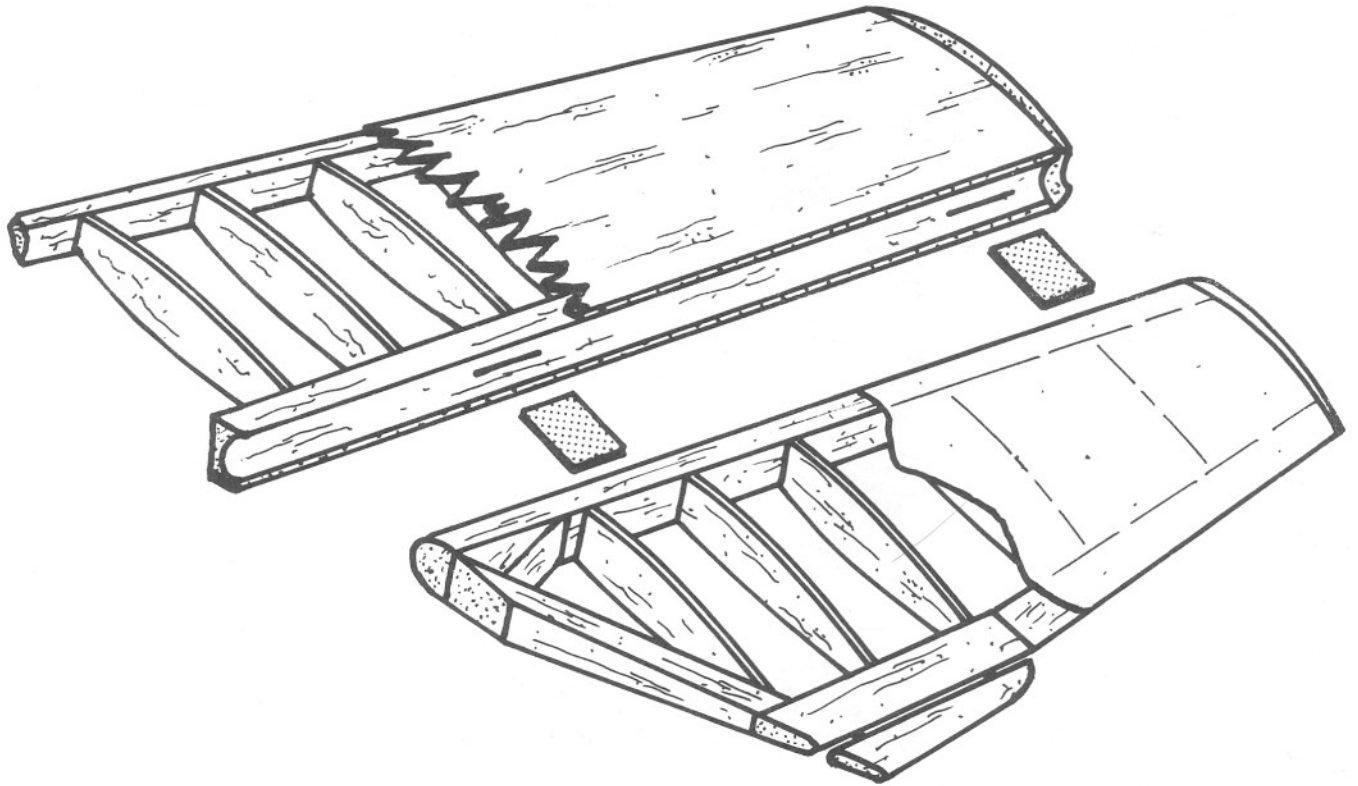

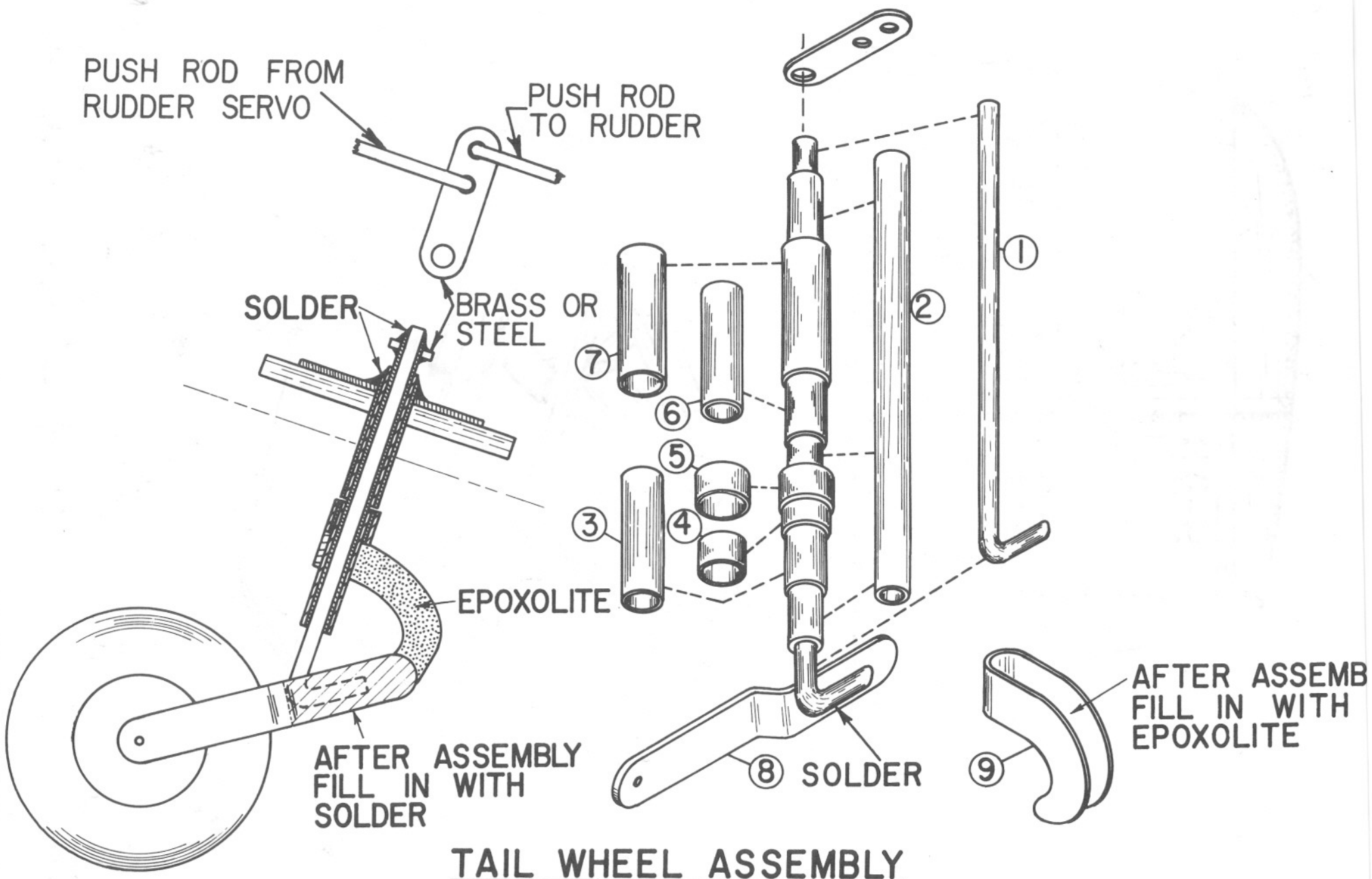

PUSH ROD FROM  
RUDDER SERVO

PUSH ROD  
TO RUDDER

SOLDER

BRASS OR  
STEEL

EPOXOLITE

AFTER ASSEMBLY  
FILL IN WITH  
SOLDER

⑦

⑥

⑤

③

④

②

①

⑧

SOLDER

⑨

AFTER ASSEMBLY  
FILL IN WITH  
EPOXOLITE

TAIL WHEEL ASSEMBLY