

DECATHLON

MS: 86

ASSEMBLY MANUAL

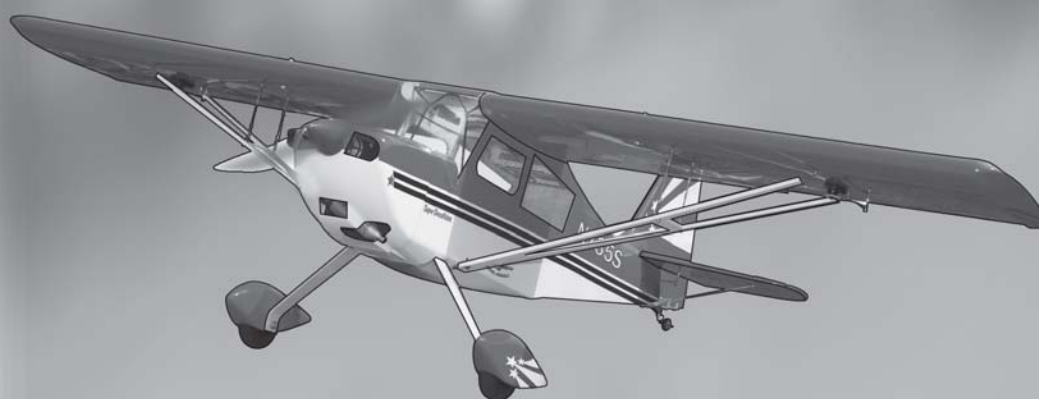

“Graphics and specifications may change without notice”.

Specifications

Wing span-----	70.9 in-----	180cm.
Wing area-----	837 sq.in-----	54 sq.dm.
Approximate flying weight-----	7.5-8.8 lbs-----	3.4-4.0kg.
Length-----	47.6in-----	121cm.
Recommended engine size-----	.75cu.in-----	2-stroke.
	.91cu.in-----	4-stroke.

Radio System required 4 channels with 6 servos
Flying skill level Intermediate/advanced.

Kit features.

- Ready-made—minimal assembly & finishing required.
- Ready-covered covering.
- Photo-illustrated step-by-step Assembly Manual.

Made in Vietnam.

FACTORY BUILT MODEL

INTRODUCTION.

Thank you for choosing the **DECATHLON** ARTF by SEAGULL MODELS. The **DECATHLON** was designed with the intermediate/advanced sport scale in mind. It is a semi scale airplane which is easy to fly and quick to assemble. The airframe is conventionally built using balsa, plywood to make it stronger than the average ARTF, yet the design allows the aeroplane to be kept light. You will find that most of the work has been done for you already. The motor mount has been fitted and the hinges are pre-installed. Flying the **DECATHLON** is simply a joy.

This instruction manual is designed to help you build a great flying aeroplane. Please read this manual thoroughly before starting assembly of your **DECATHLON**. Use the parts listing below to identify all parts.

WARNING.

Please be aware that this aeroplane is not a toy and if assembled or used incorrectly it is capable of causing injury to people or property. WHEN YOU FLY THIS AEROPLANE YOU ASSUME ALL RISK & RESPONSIBILITY.

If you are inexperienced with basic R/C flight we strongly recommend you contact your R/C supplier and join your local R/C Model Flying Club. R/C Model Flying Clubs offer a variety of training procedures designed to help the new pilot on his way to successful R/C flight. They will also be able to advise on any insurance and safety regulations that may apply.

ADDITIONAL ITEMS REQUIRED.

- .75cu.in 2-stroke engine
- .91cu.in 4-stroke
- 4 channel with 6 servos
- Glow plug to suit engine
- Propeller to suit engine
- Protective foam rubber for radio system
- Silicone fuel line

TOOLS & SUPPLIES NEEDED.

- Thick cyanoacrylate glue
- 30 minute epoxy
- 5 minute epoxy
- Hand or electric drill
- Assorted drill bits
- Modelling knife
- Straight edge ruler
- 2mm ball driver
- Phillips head screwdriver
- 220 grit sandpaper
- 90° square or builder's triangle
- Wire cutters
- Masking tape & T-pins
- Thread-lock
- Paper towels

PARTS LISTING.**FUSELAGE ASSEMBLY**

- (1) Fuselage

WING ASSEMBLY

- (1) Right wing
- (1) Left wing
- (1) Aluminium dihedral brace

Tail section assembly

- (1) Horizontal stabilizer/ elevator halves.
- (1) Rudder halves.

Some more parts.**HARDWARE PACK****COWLING**

Landing gear.....

NOTE: To avoid scratching your new aeroplane we suggest that you cover your workbench with an old towel. Keep a couple of jars or bowls handy to hold the small parts after you open the bags.

Please trial fit all parts. Make sure you have the correct parts and that they fit and are aligned properly before gluing! This will ensure proper assembly as the **DECATHLON** is made from natural materials and minor adjustments may have to be made. The paint and plastic parts used in this kit are fuel proof. However, they are not tolerant of many harsh chemicals including the following: paint thinner, cyano-acrylate glue accelerator, cyanoacrylate glue de-bonder and acetone. Do not let these chemicals come in contact with the colours on the covering and the plastic parts.

HINGING THE AILERONS.

Note: *The control surfaces, including the ailerons, elevators, and rudder, are prehinged with hinges installed, but the hinges are not glued in place. It is imperative that you properly adhere the hinges in place per the steps that follow using a high-quality thin C/A glue.*

□ 1) Carefully remove the aileron from one of the wing panels. Note the position of the hinges.

□ 2) Remove each hinge from the wing panel and aileron and place a T-pin in the center of each hinge. Slide each hinge into the wing panel until the T-pin is snug against the wing panel. This will help ensure an equal amount of hinge is on either side of the hinge line when the aileron is mounted to the aileron.

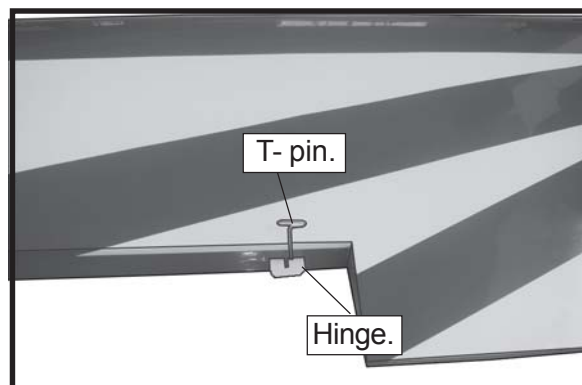

□ 3) Slide the wing panel on the aileron until there is only a slight gap. The hinge is now centered on the wing panel and aileron. Remove the T-pins and snug the aileron against the wing panel. A gap of 1/64" or less should be maintained between the wing panel and aileron.

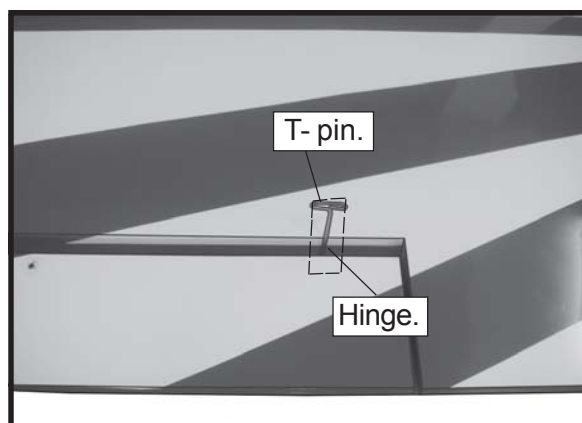

□ 4) Deflect the aileron and completely saturate each hinge with thin C/A glue. The aileron's front surface should lightly contact the wing during this procedure. Ideally, when the hinges are glued in place, a 1/64" gap or less will be maintained throughout the length of the aileron to the wing panel hinge line.

Note: *The hinge is constructed of a special material that allows the C/A to wick or penetrate and distribute throughout the hinge, securely bonding it to the wood structure of the wing panel and aileron.*

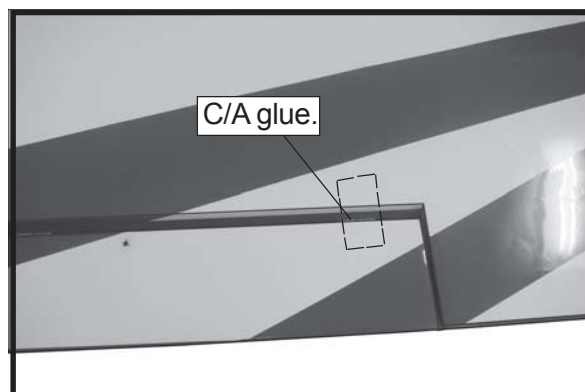

□ 5) Turn the wing panel over and deflect the aileron in the opposite direction from the opposite side. Apply thin C/A glue to each hinge, making sure that the C/A penetrates into both the aileron and wing panel.

□ 6) Using C/A remover/debonder and a paper towel, remove any excess C/A glue that may have accumulated on the wing or in the aileron hinge area.

□ 7) Repeat this process with the other wing panel, securely hinging the aileron in place.

□ 8) After both ailerons are securely hinged, firmly grasp the wing panel and aileron to make sure the hinges are securely glued and cannot be pulled out. Do this by carefully applying medium pressure, trying to separate the aileron from the wing panel. Use caution not to crush the wing structure.

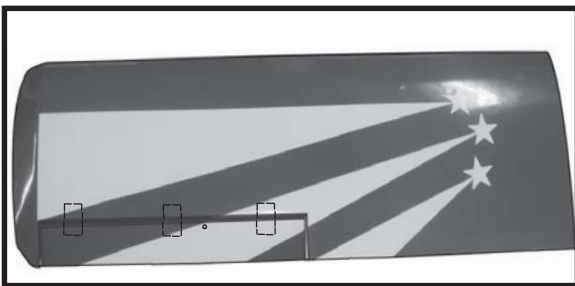

Note: *Work the aileron up and down several times to "work in" the hinges and check for proper movement.*

TURNBUCKLE INSTALLATION.

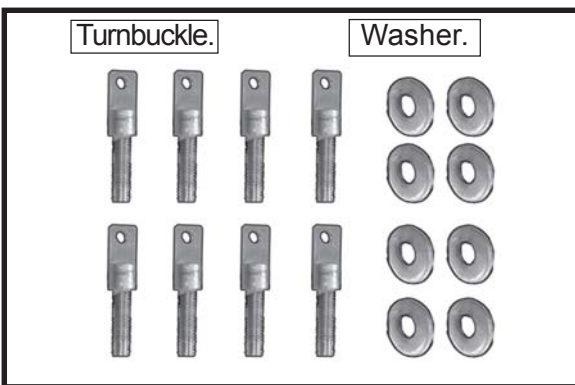

The hole location of turnbuckles shown in picture below .

Installing the turnbuckle for the wing as same as pictures below.

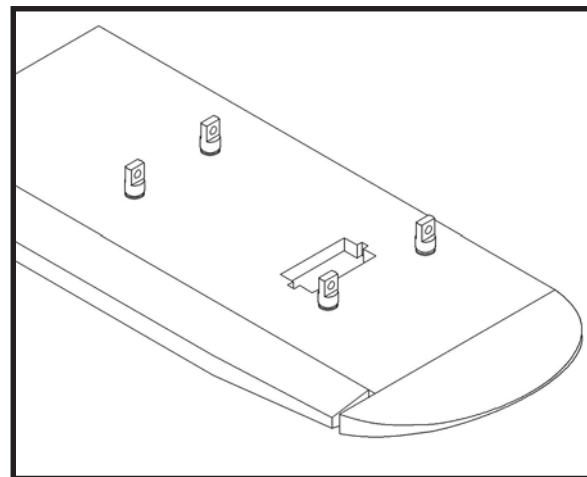
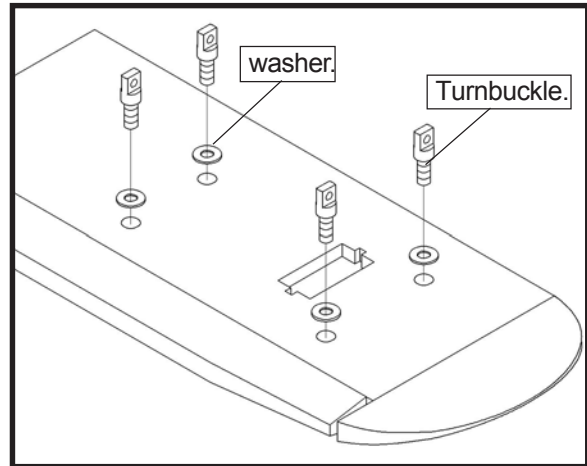

TURNBUCKLE INSTALLATION.



The hole location of turnbuckles shown in picture below .

! *The mounting holes of turnbuckle was pre-drilled at factory.*

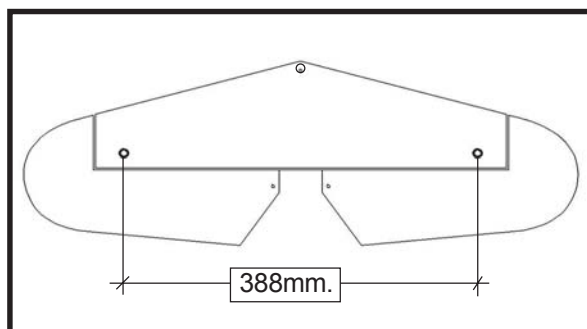

Installing the turnbuckle for tail strut of horizontal fin as same as pictures below.

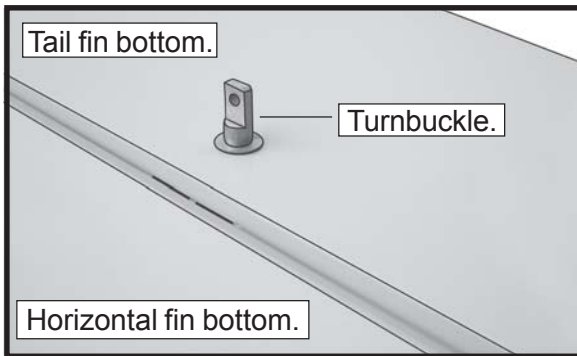

HINGING THE RUDDER.

Glue the rudder hinges in place using the same techniques used to hinge the ailerons.

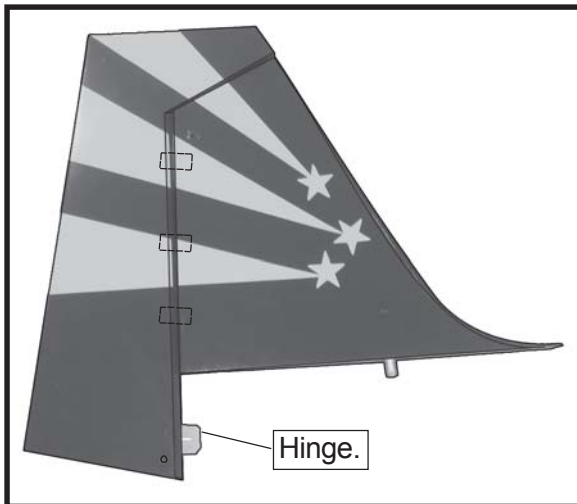

AILERON CONTROL HORN

Aileron control horn: See pictures below.

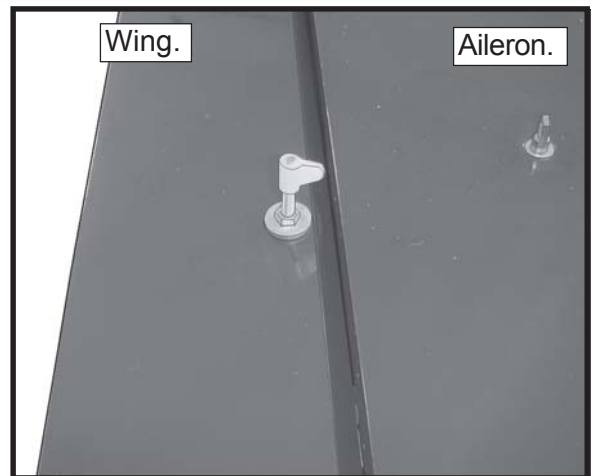
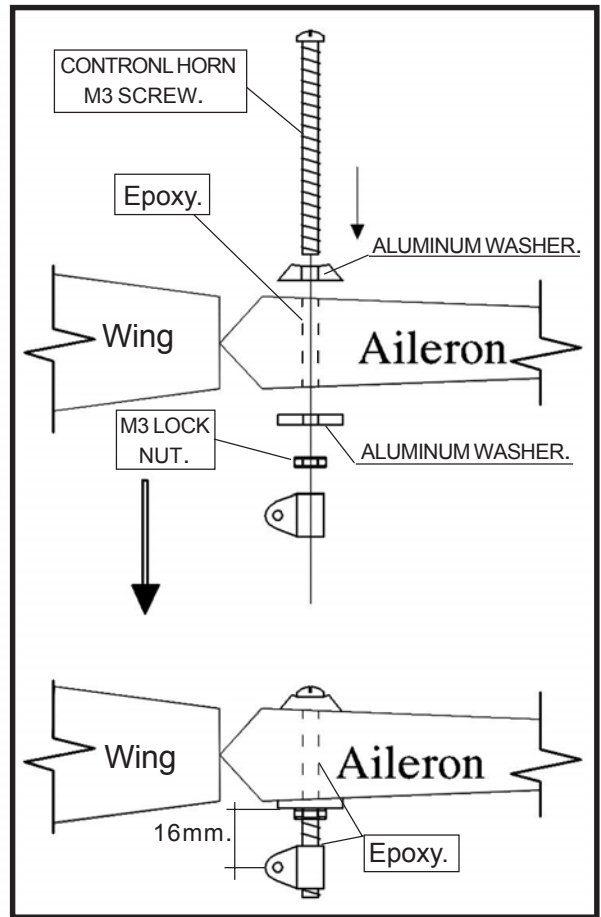
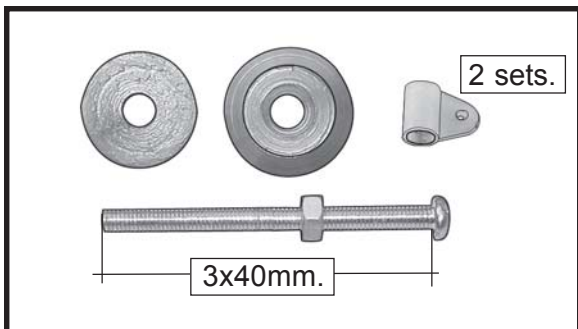

ELEVATOR CONTROL HORN.

Install the elevator control horn using the same method as with the aileron control horns.

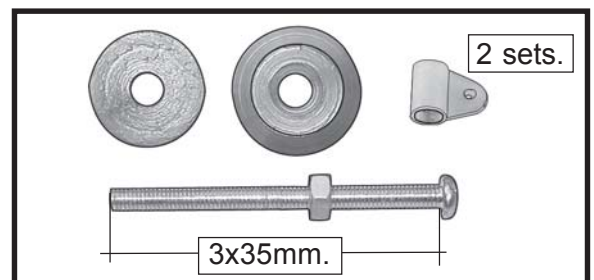

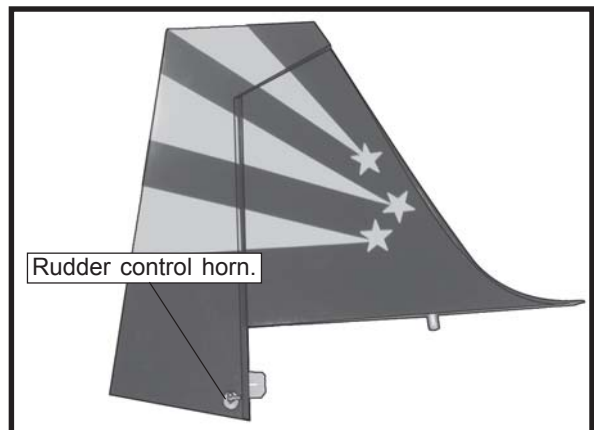
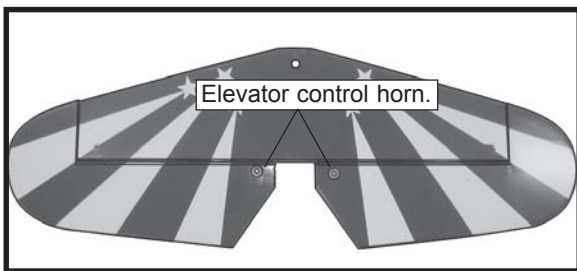
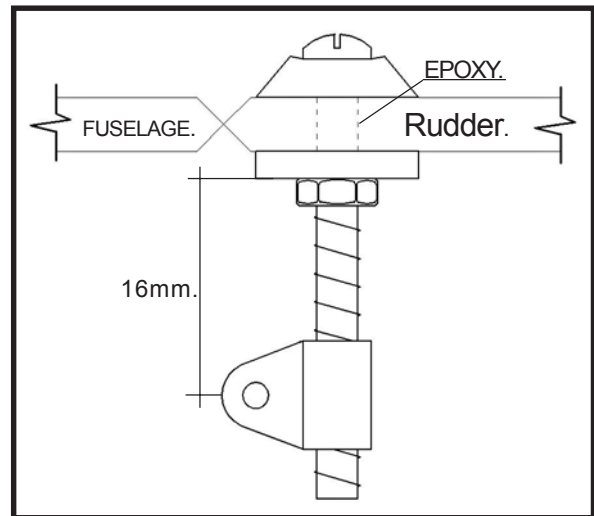
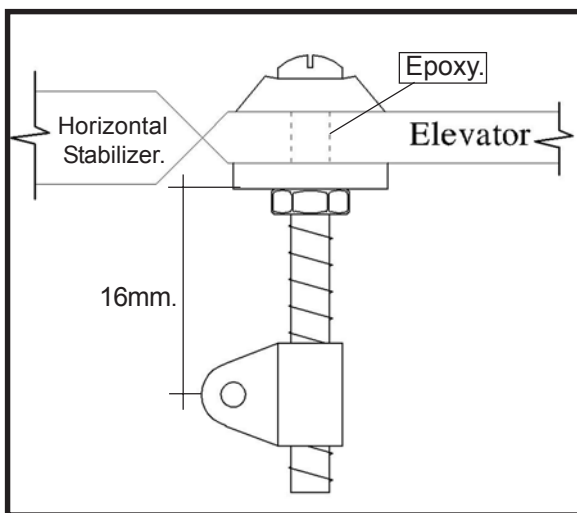
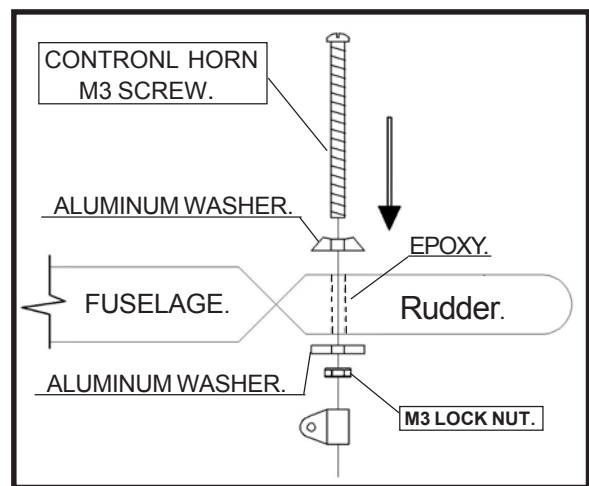
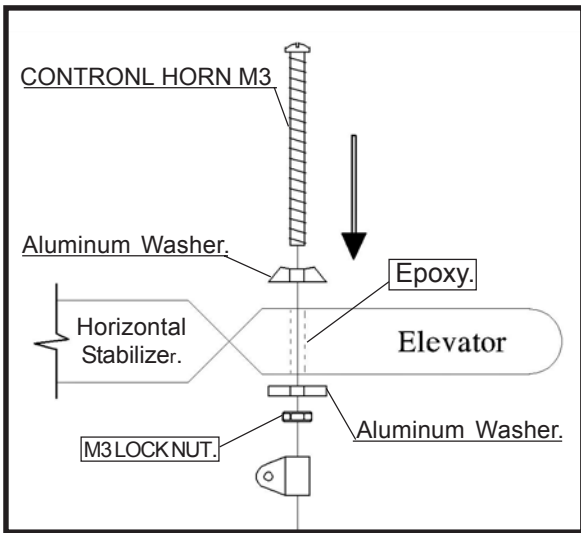

RUDDER CONTROL HORN.

ENGINE MOUNT INSTALLATION.

Rudder control horn:
Using the same techniques used aileron control horn. See picture below.

See pictures below. Make yourself the template of your engine on paper.

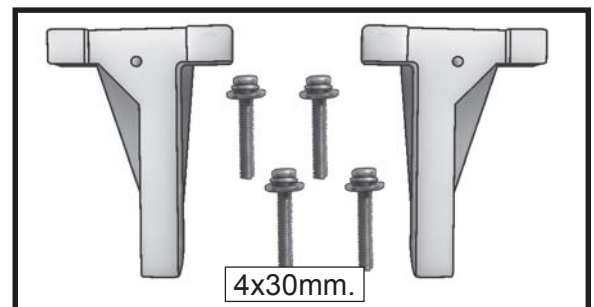
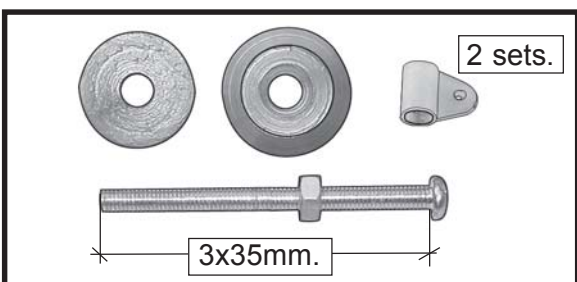

Mark and drill 4 holes for engine mount.
Insert 4 blind nuts to firewall.

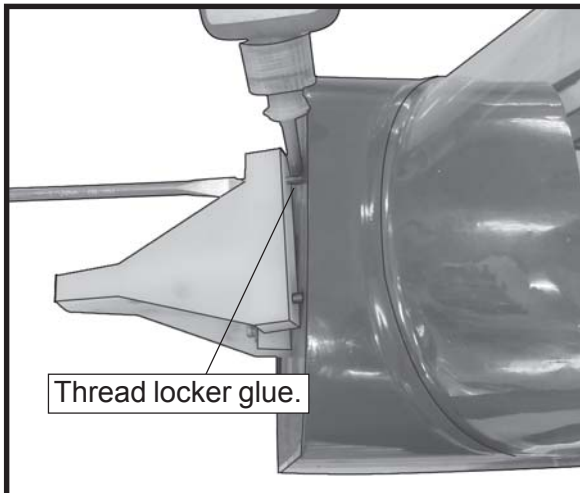

Thread locker glue.



INSTALLING THE STOPPER ASSEMBLY.

- 1) Using a modeling knife, carefully cut off the rear portion of one of the 3 nylon tubes leaving 1/2" protruding from the rear of the stopper. This will be the fuel pick up tube.
- 2) Using a modeling knife, cut one length of silicon fuel line. Connect one end of the line to the weighted fuel pick up and the other end to the nylon pick up tube. (The silicon tube is not included).
- 3) Carefully bend the second nylon tube up at a 45° angle. This tube is the vent tube.

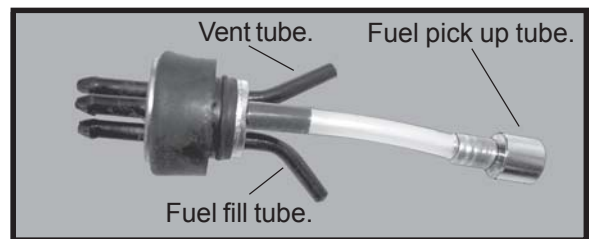
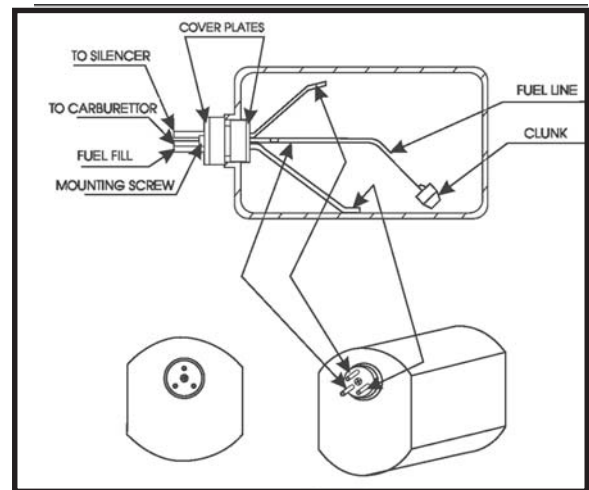
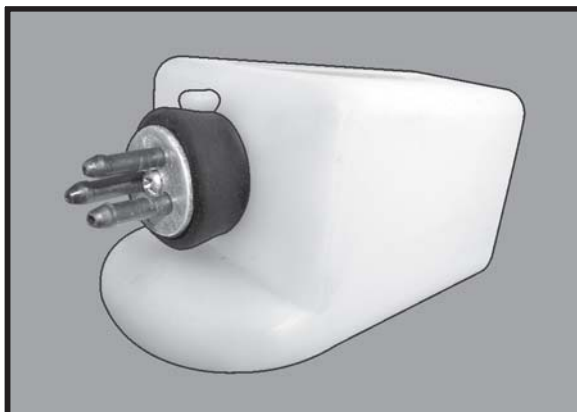

Carefully use a lighter or heat gun to permanently set the angle of the vent tube.

Important: When the stopper assembly is installed in the tank, the top of the vent tube should rest just below the top surface of the tank. It should not touch the top of the tank.

- 4) Test fit the stopper assembly into the tank. It may be necessary to remove some of the flashing around the tank opening using a modeling knife. If flashing is present, make sure none falls into the tank.
- 5) With the stopper assembly in place, the weighted pick-up should rest away from the rear of the tank and move freely inside the tank. The top of the vent tube should rest just below the top of the tank. It should not touch the top of the tank.
- 6) When satisfied with the alignment of the stopper assembly tighten the 3 x 20mm machine screw until the rubber stopper expands and seals the tank opening. Do not overtighten the assembly as this could cause the tank to split.

FUEL TANK INSTALLATION.

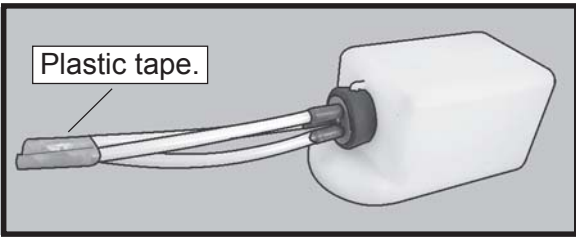

! *You should mark which tube is the vent and which is the fuel pickup when you attach fuel tubing to the tubes in the stopper. Once the tank is installed inside the fuselage, it may be difficult to determine which is which.*

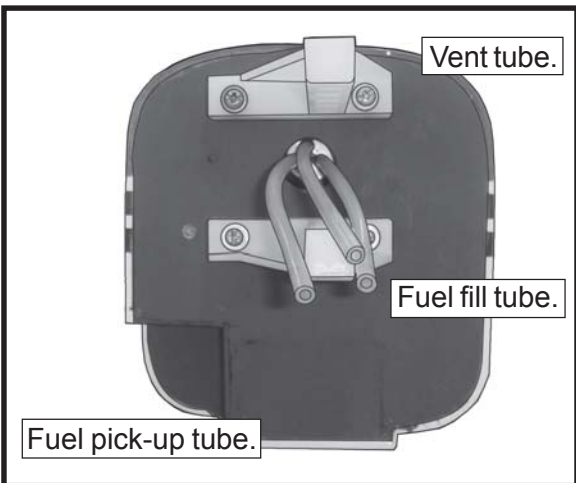
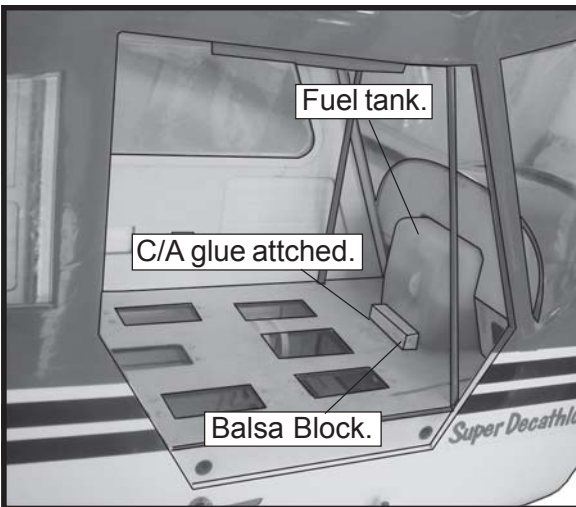

! *Blow through one of the lines to ensure the fuel lines have not become kinked inside the fuel tank compartment. Air should flow through easily.*

WHEEL AND WHEEL PANTS INSTALLATION.

□ 1) Assemble and mounting the wheel pants as shown in the following pictures.

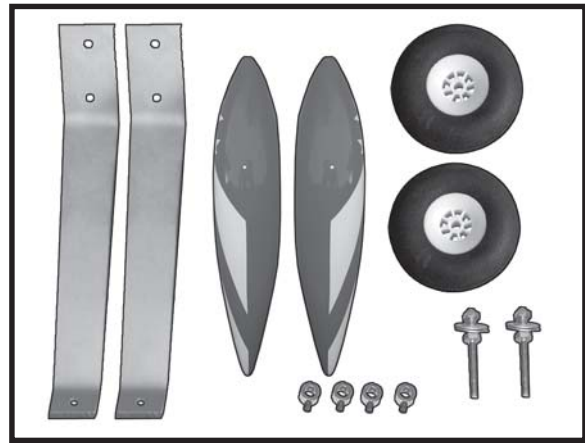

□ 2) Follow diagram below for wheel pant installation:

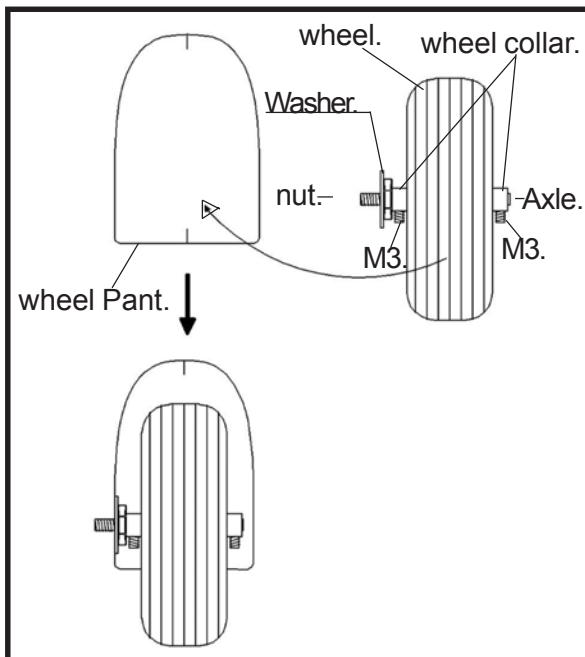
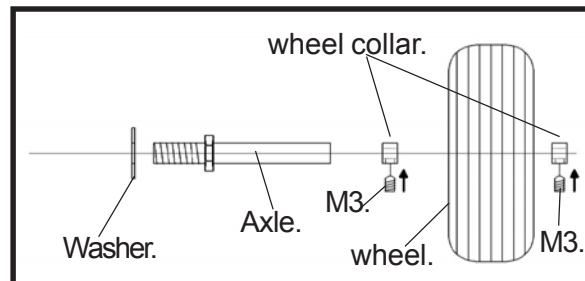
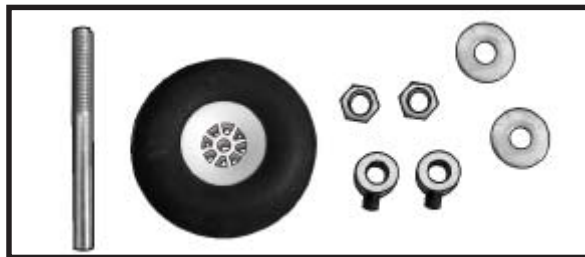
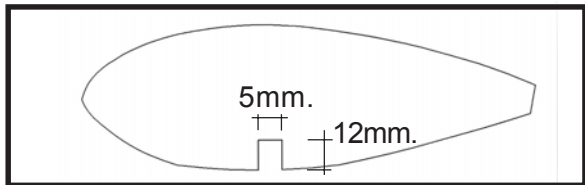

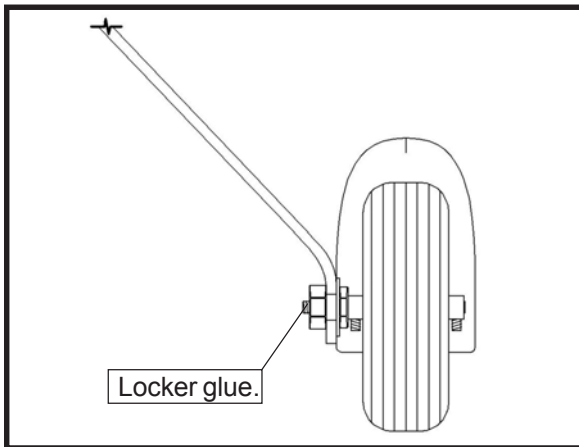
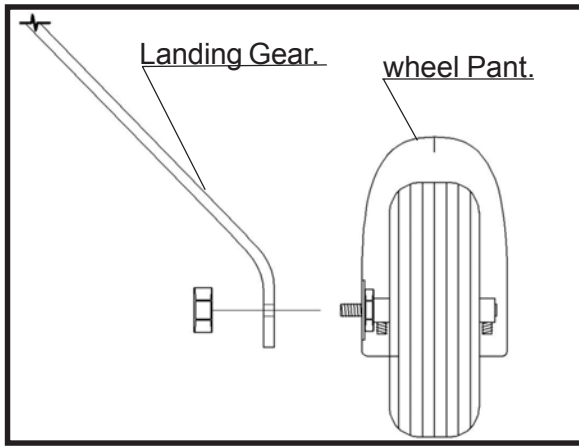

3) A drop of C/A glue on the wheel collar screws will help keep them from coming loose during operation.

Repeat the process for the other wheel.

INSTALLING THE MAIN LANDING GEAR.

- 1) The blind nuts for securing the landing gear are already mounted inside the fuselage.
- 2) Using the hardware provided, mount the main landing gear to the fuselage.

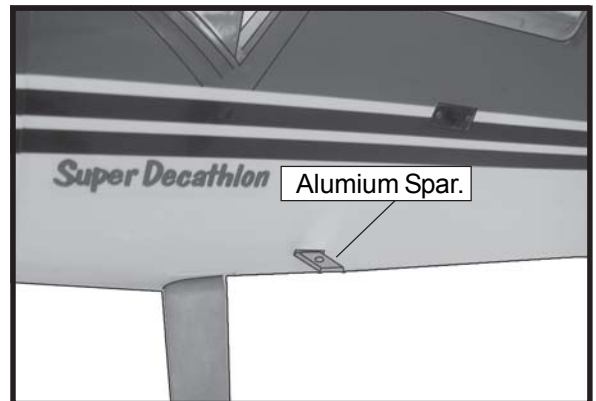
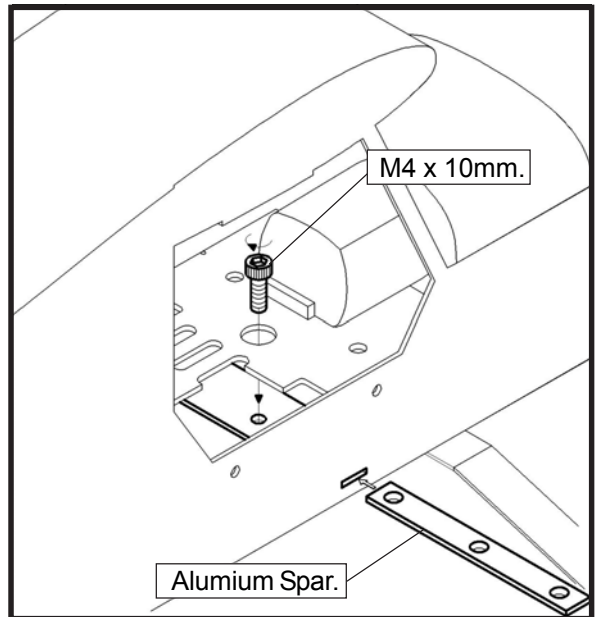
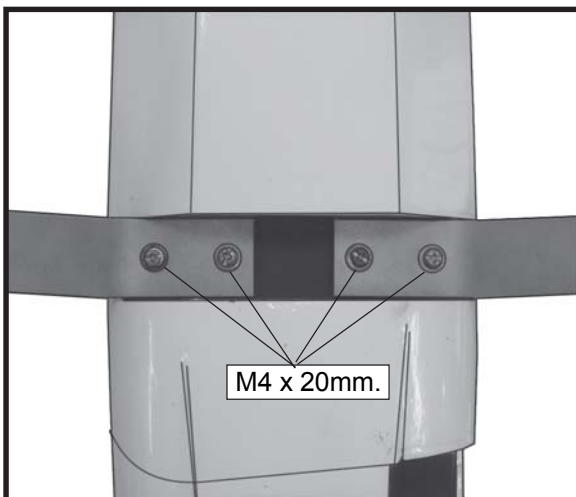

MOUNTING THE ENGINE.

- 1) Place your engine onto the engine mount. Adjust the engine is centered of the edges of the engine case.
- 2) When you are satisfied with the alignment, mark the locations of the engine mounting.
- 3) Remove the engine. Using an drill bit, drill the mounting holes through the engine mount at the four locations marked.

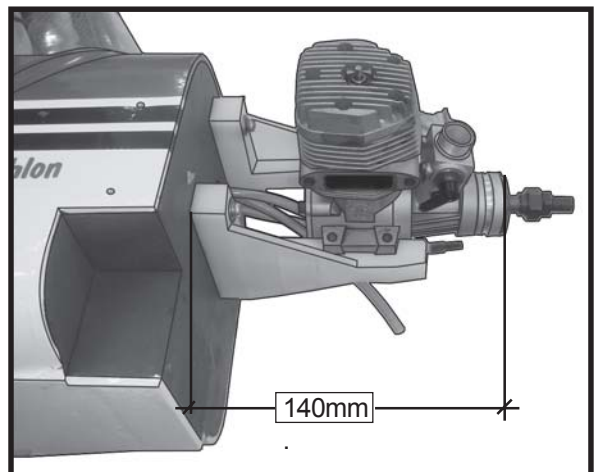

□ 4) Bolt the engine to the engine mount using the four machine screws. Double check that all the screws are tight before proceeding.

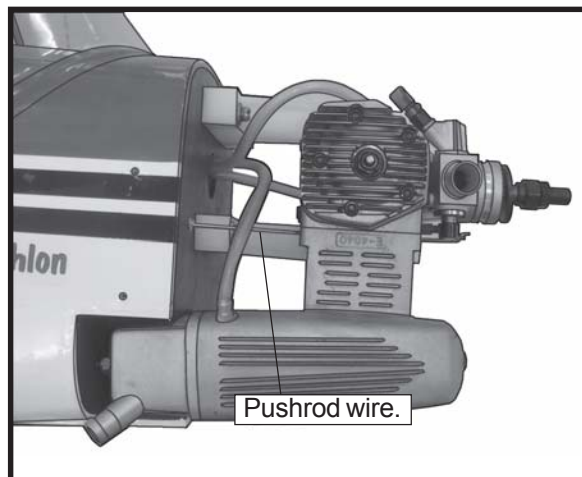
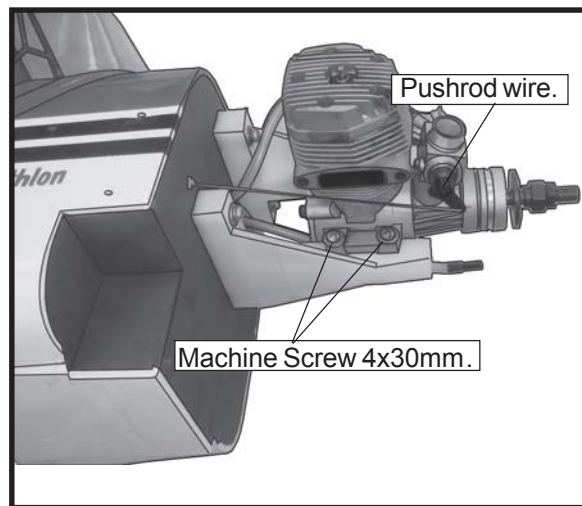
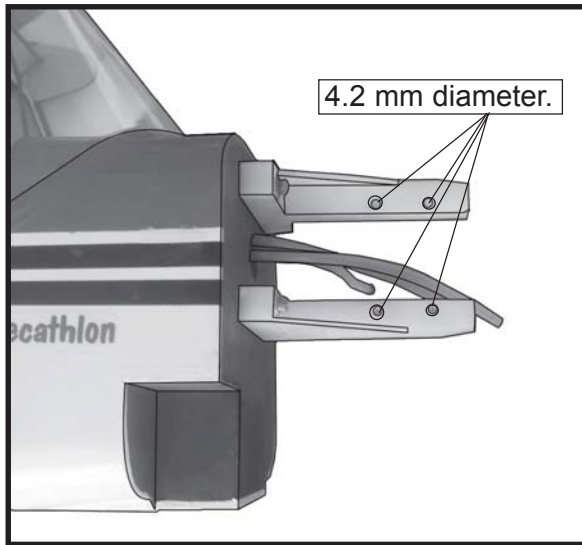

COWLING INSTALLATION.

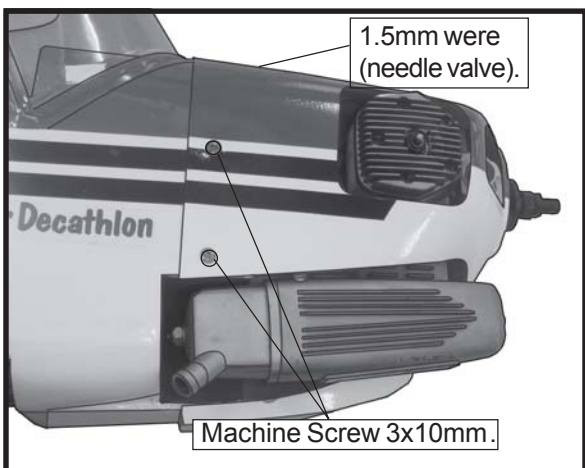
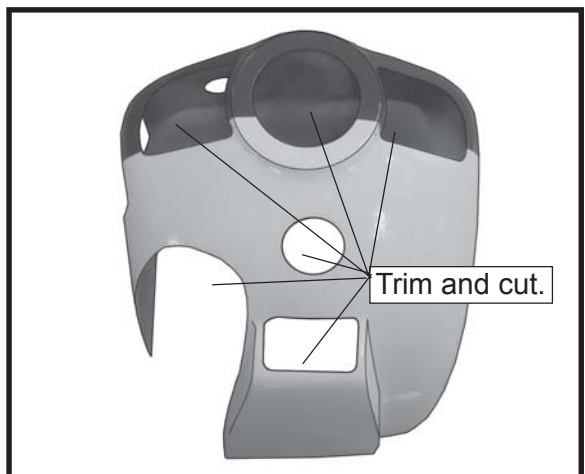
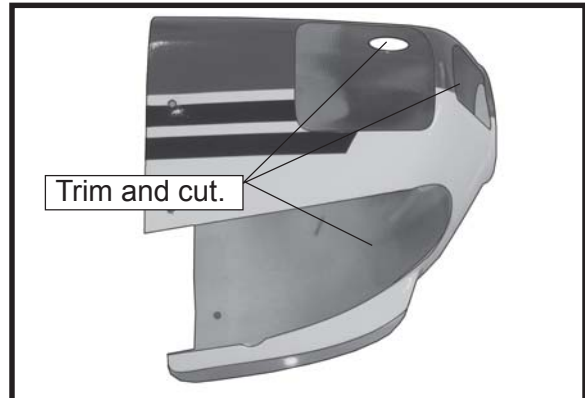

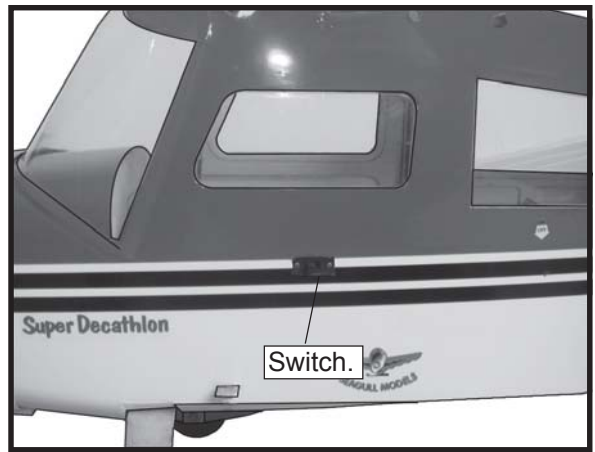

INSTALLING THE FUSELAGE SERVO.

! *Because the size of servos differ, you may need to adjust the size of the precut opening in the mount. The notch in the sides of the mount allow the servo lead to pass through.*

- 1) Install the rubber grommets and brass collets onto the throttle servo. Test fit the servo into the aileron servo mount.
- 2) Secure the servos with the screws provided with your radio system.

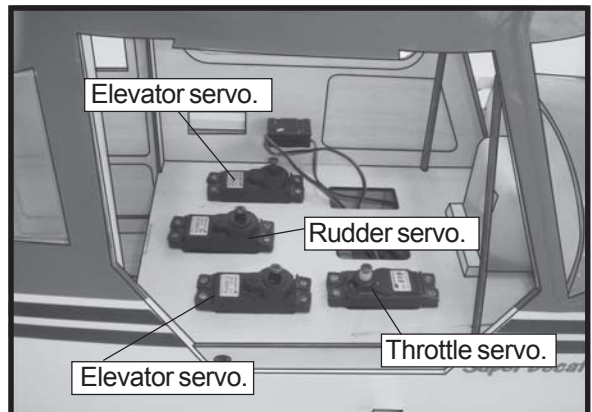

INSTALLING THE SWITCH.

Install the switch into the precut hole in the side of fuselage.



THROTTLE SERVO ARM INSTALLATION.

Install adjustable servo connector in the servo arm .

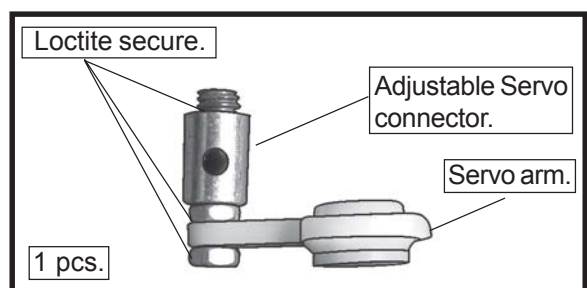

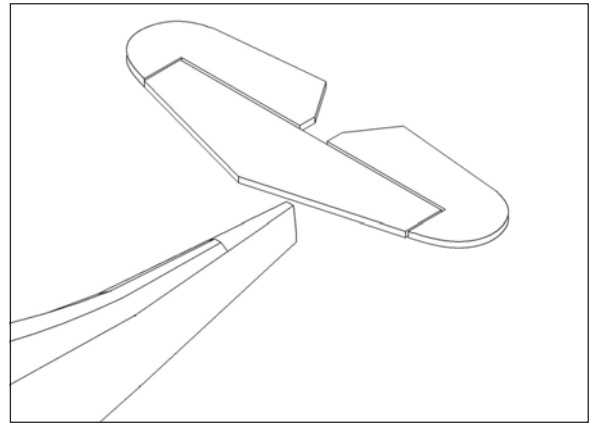
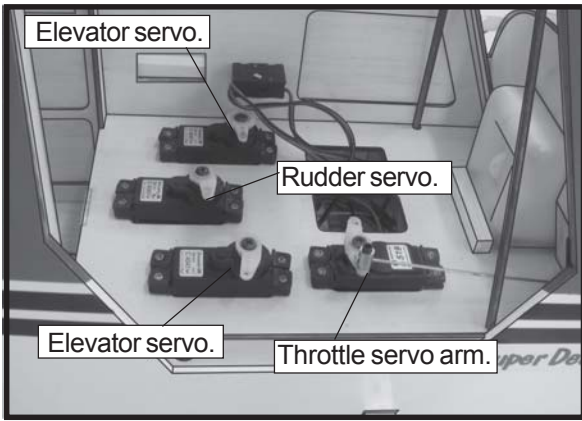

INSTALLING THE HORIZONTAL STABILIZER.

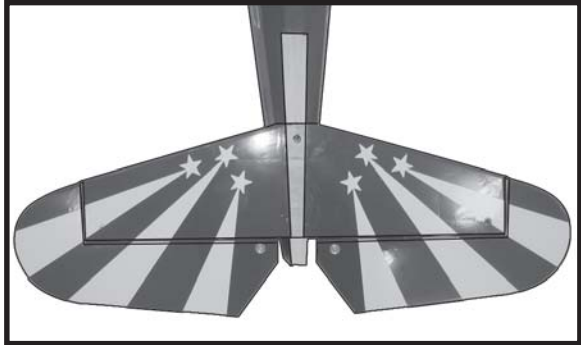
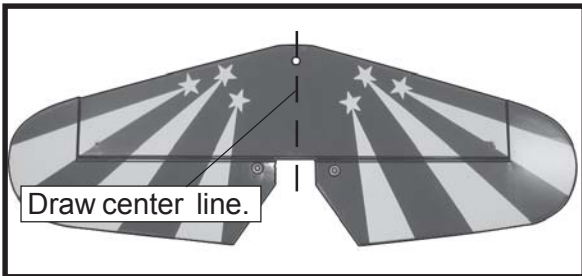

! *When cutting through the covering to remove it, cut with only enough pressure to only cut through the covering itself. Cutting into the balsa structure may weaken it.*

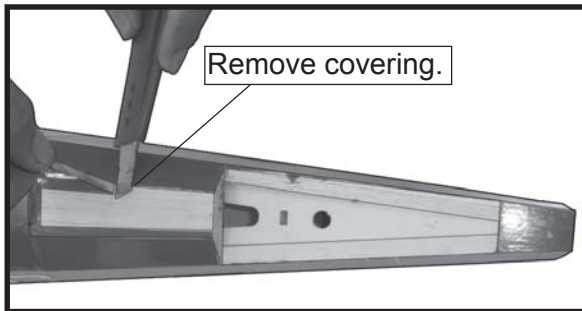

INSTALLING THE VERTICAL STABI-

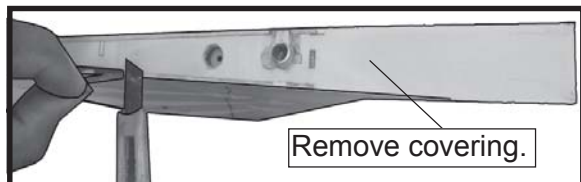
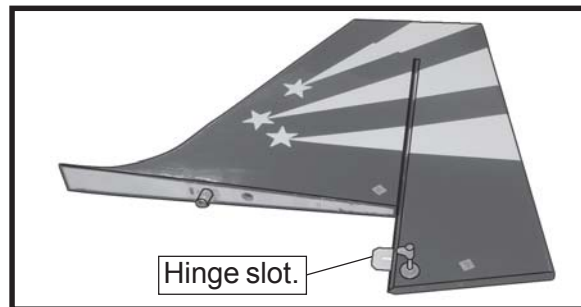
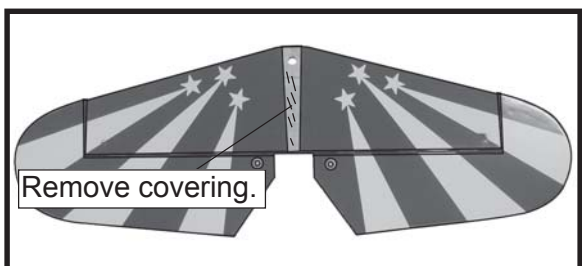
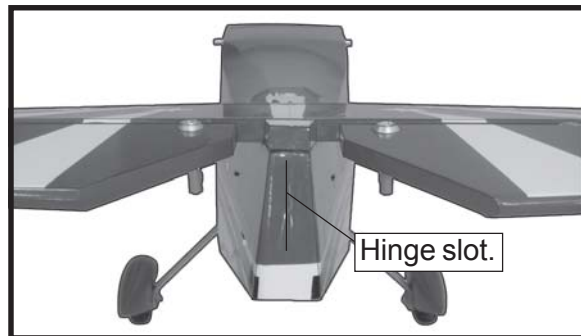
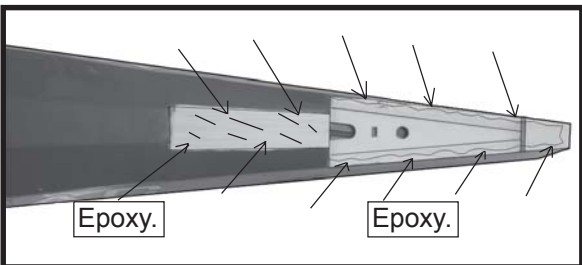

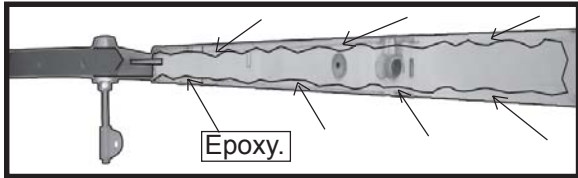

! *When cutting through the covering to remove it, cut with only enough pressure to only cut through the covering itself. Cutting into the balsa structure may weaken it.*

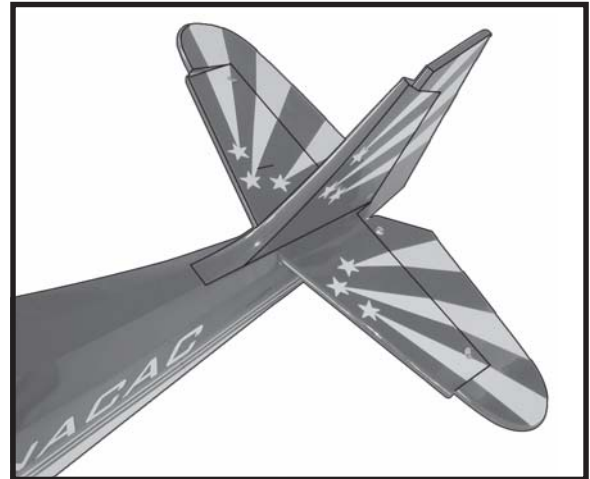
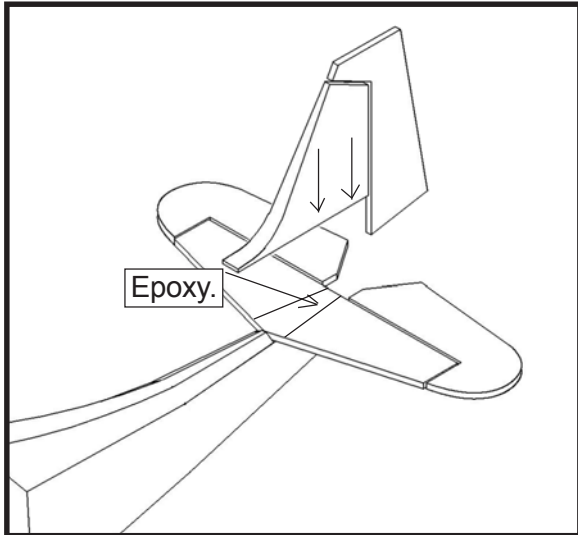
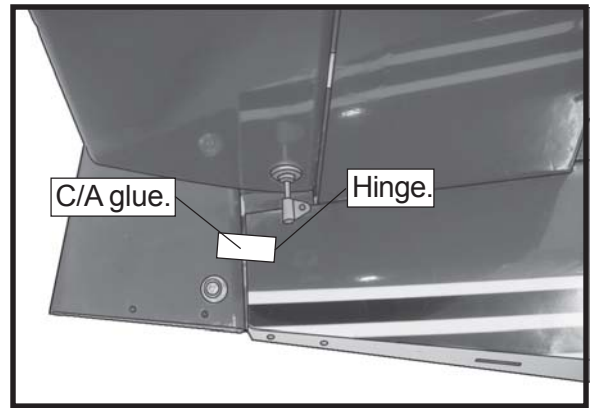

Put the vertical stabilizer into the in the top of the horizontal fin. The bottom edge of the stabilizer should also be firmly pushed against the top of the horizontal stabilizer.

INSTALLING THE AILERON SERVOS.

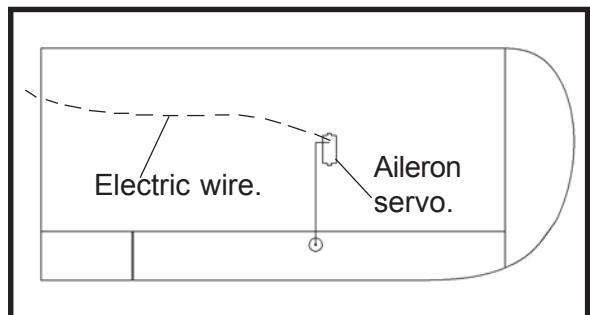
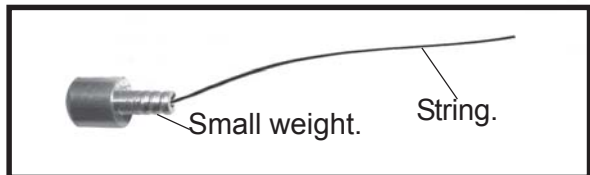
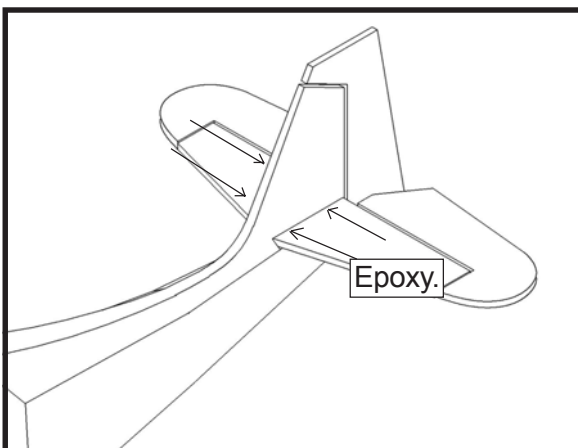
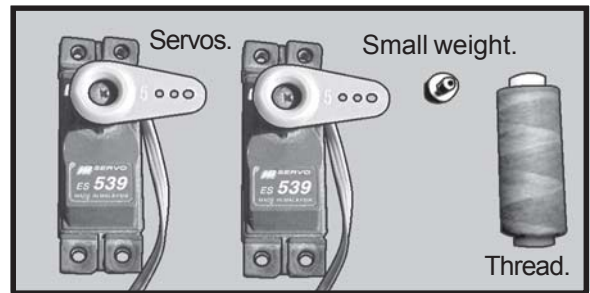
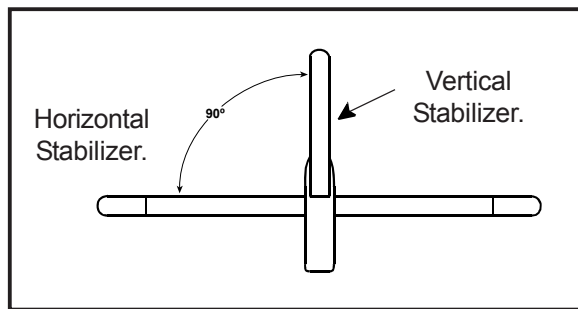

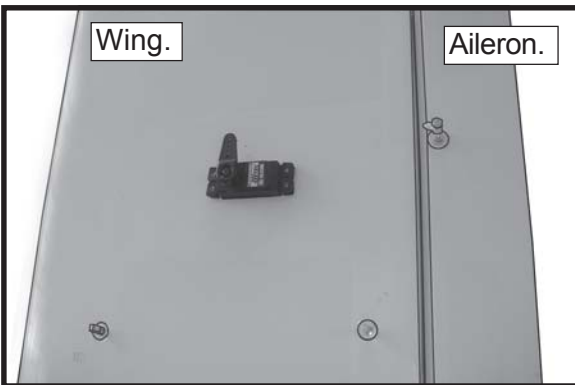
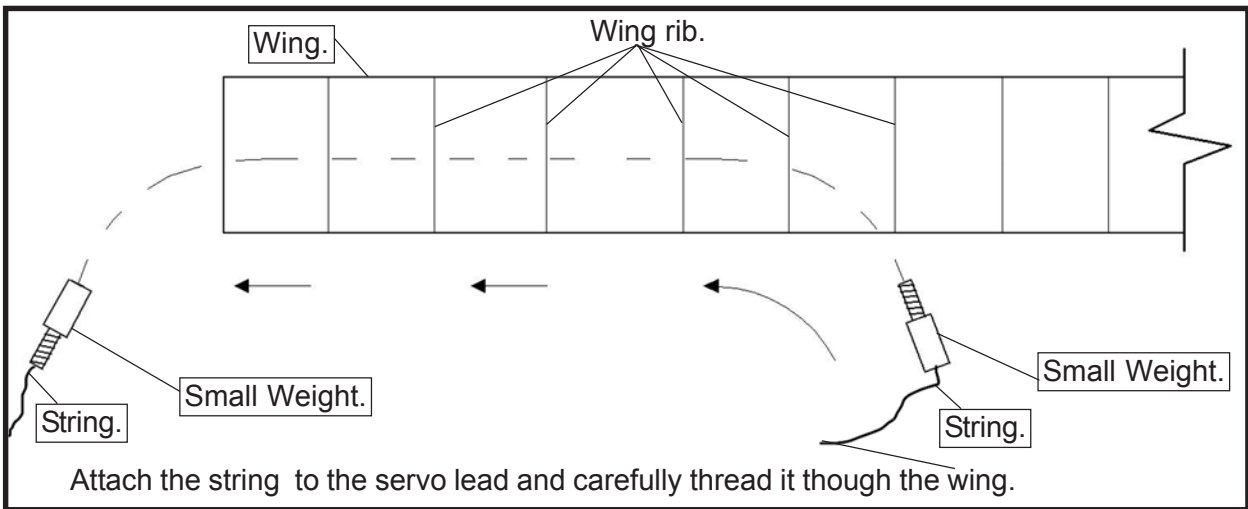

INSTALLATION THE PUSHROD.

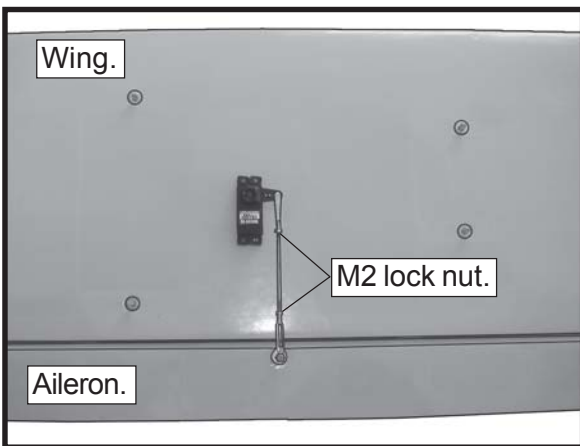
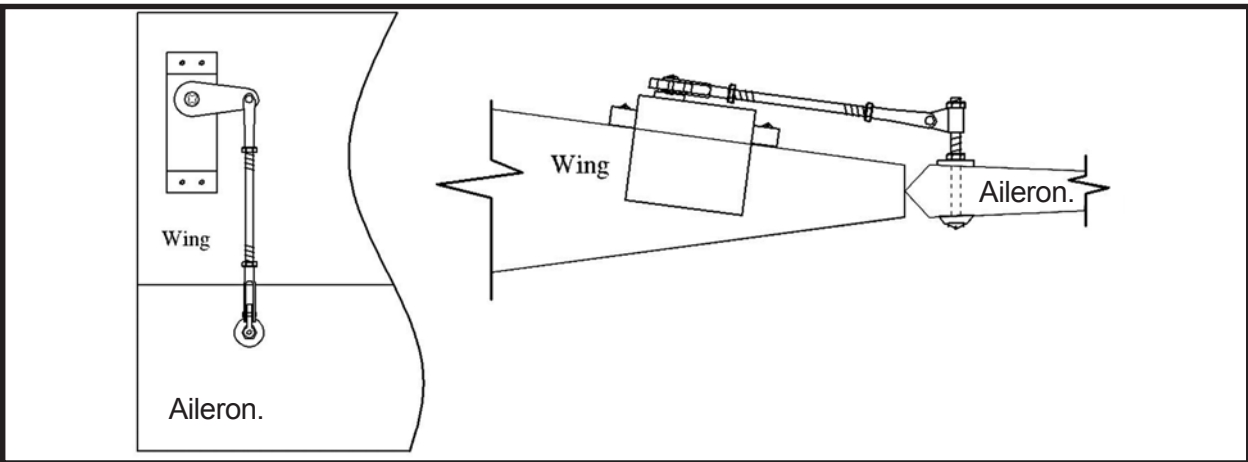
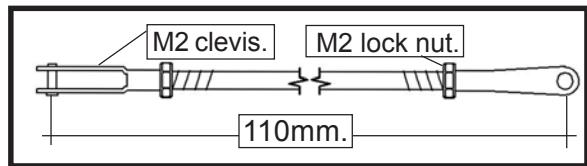
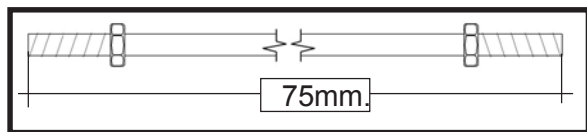

ELEVATOR - RUDDER PUSHROD INSTALLATION.

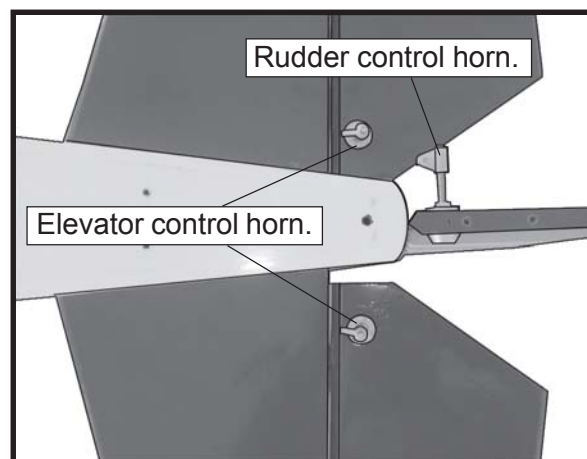

Repeat the procedure for the other wing.

- 1) Elevator and rudder pushrods assembly follow pictures below.

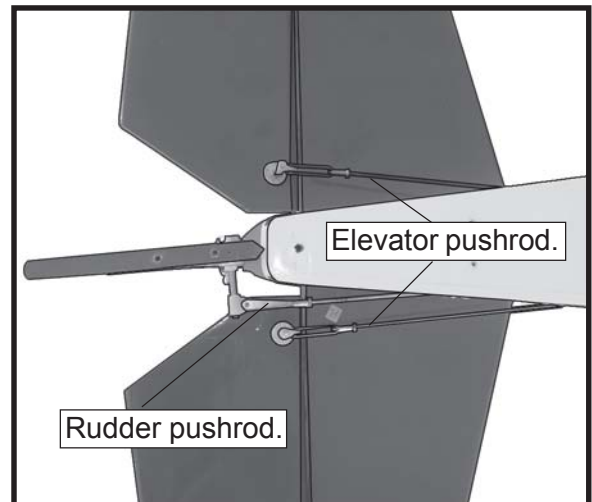
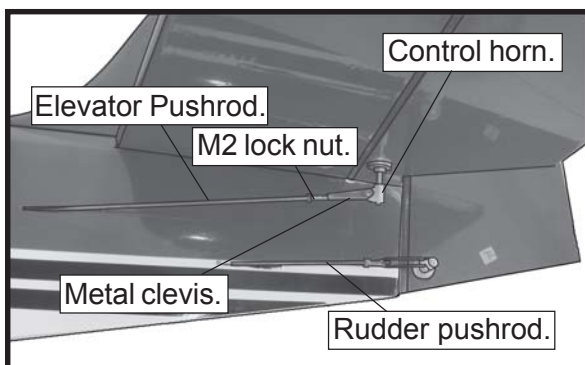
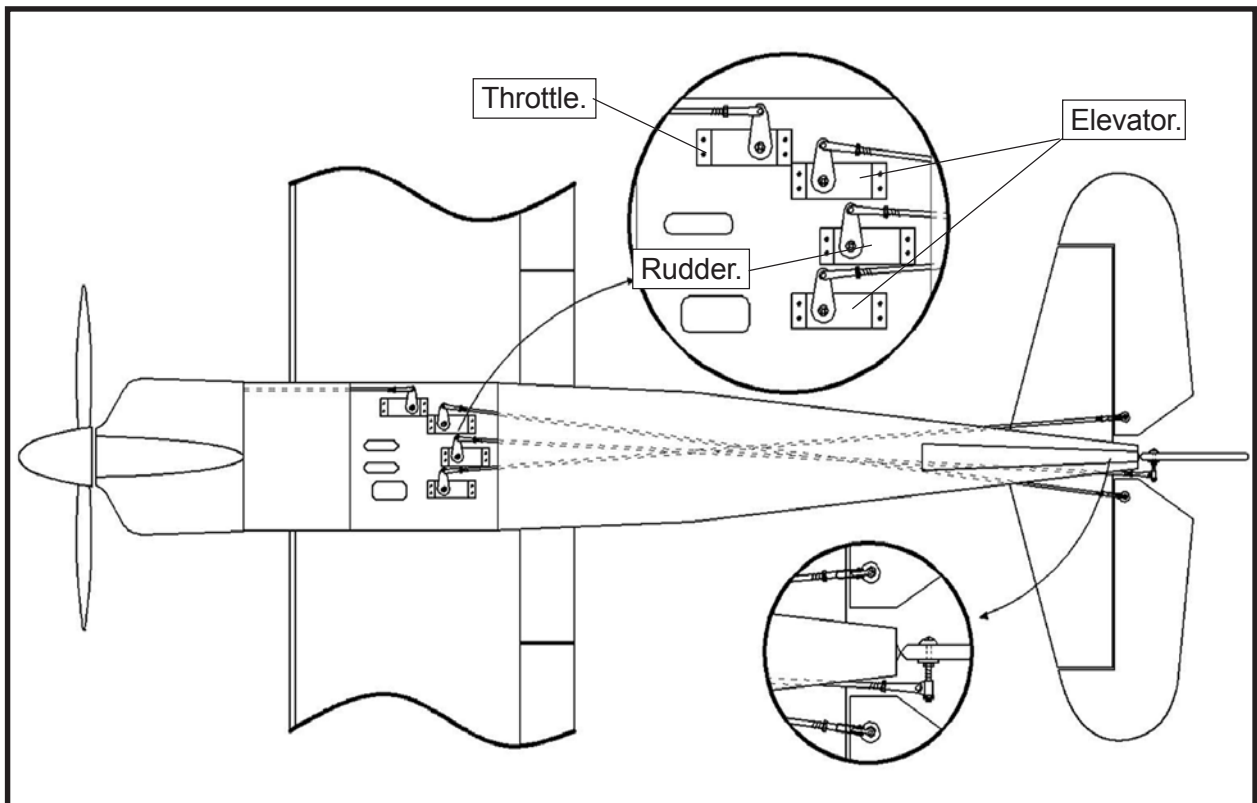
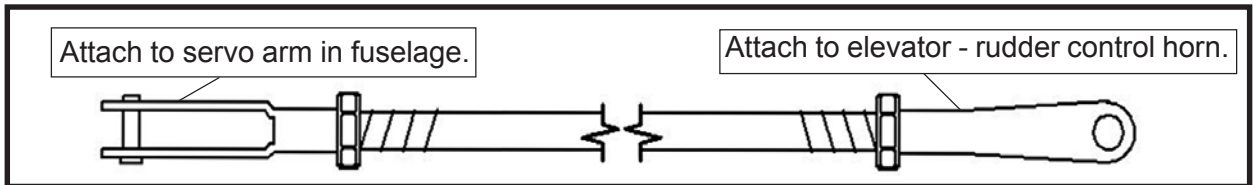
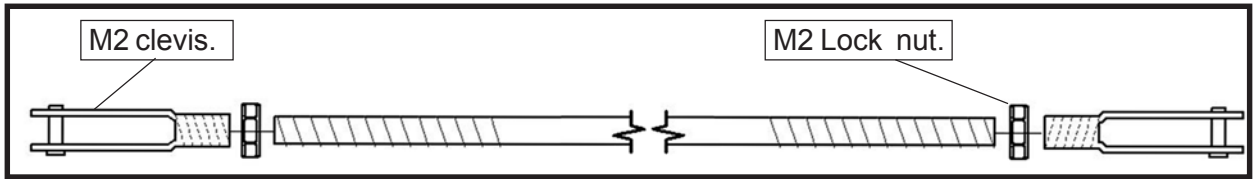

- 2) Install servos arm to servos. Notice the position of the servo arms on the servos. See picture below.

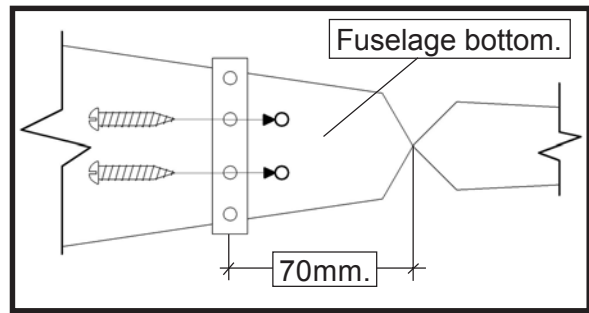
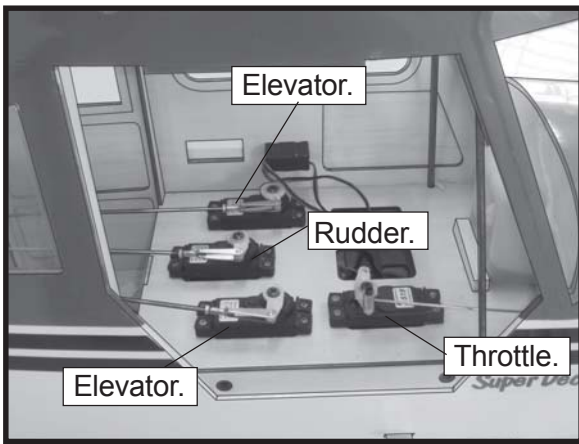

INSTALLING TAIL STRUT SUPPORT

The tail strut system assembly follow pictures below.

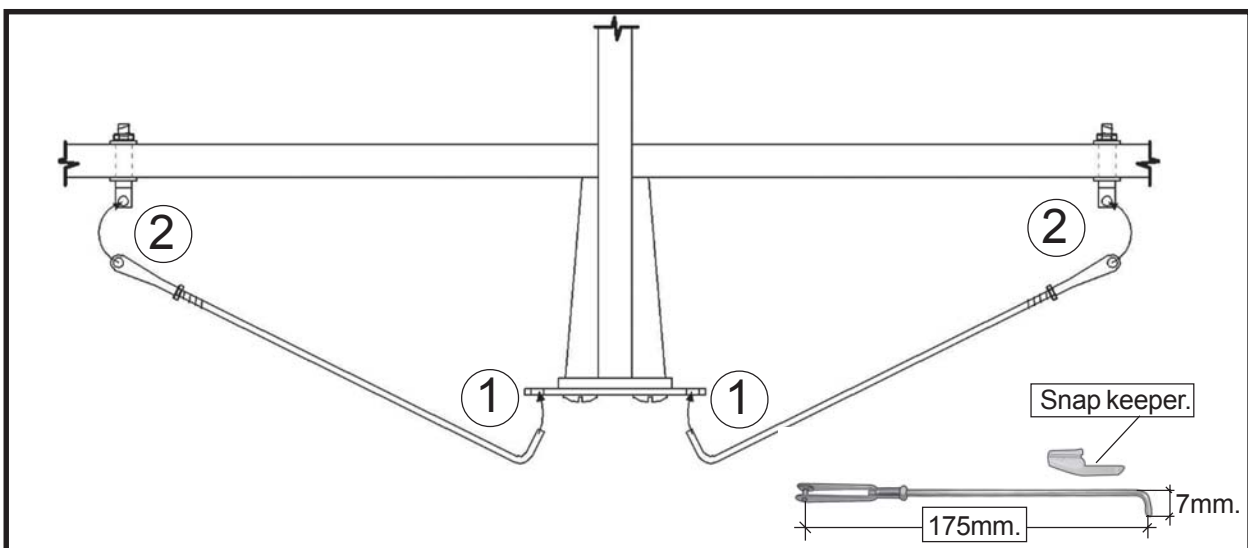
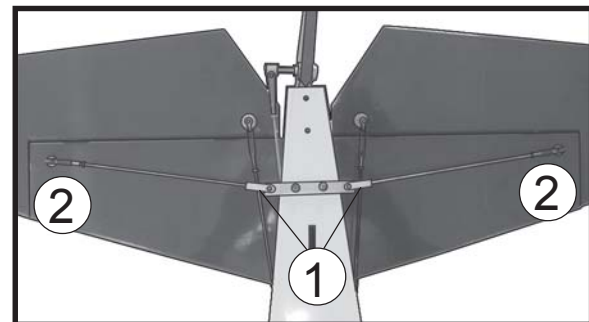
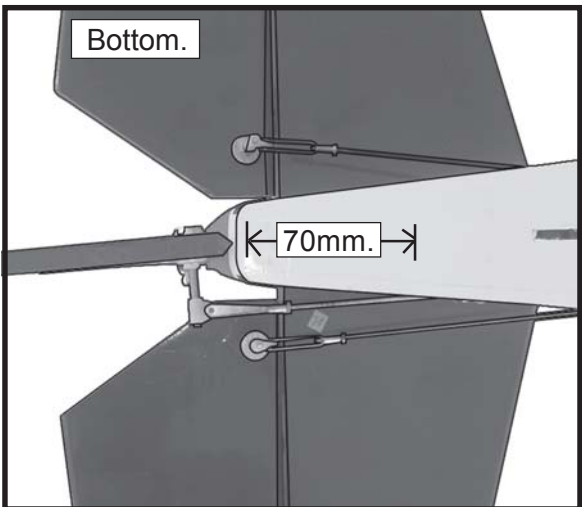
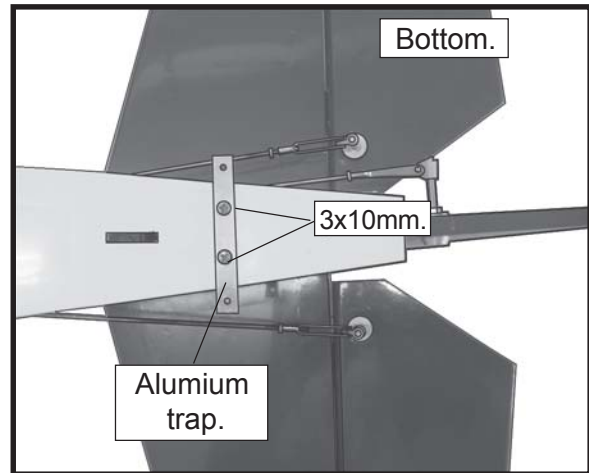
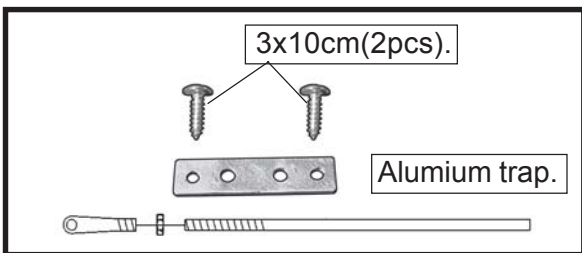

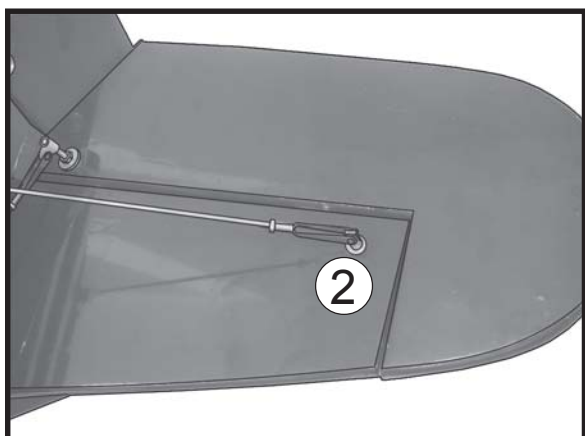
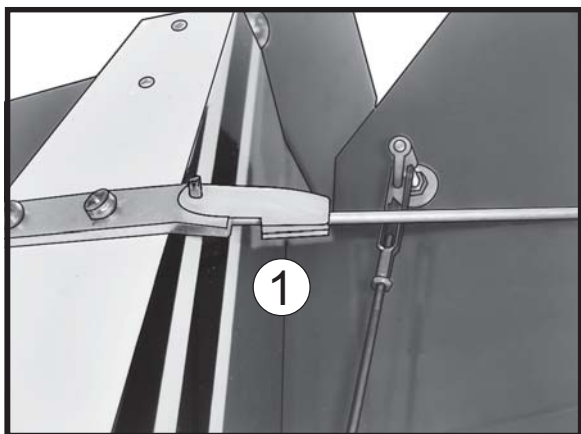
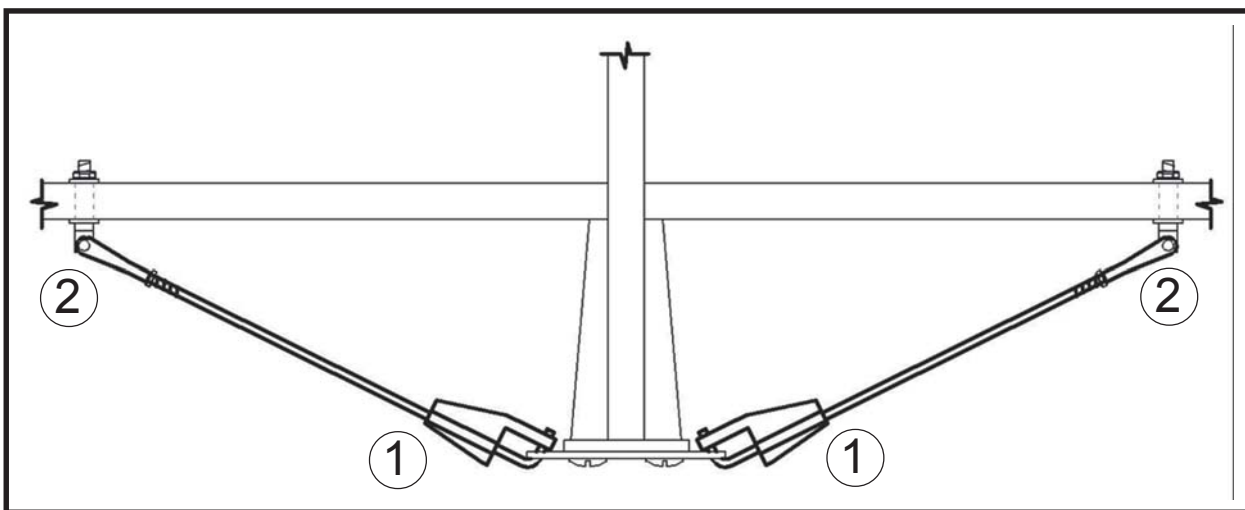
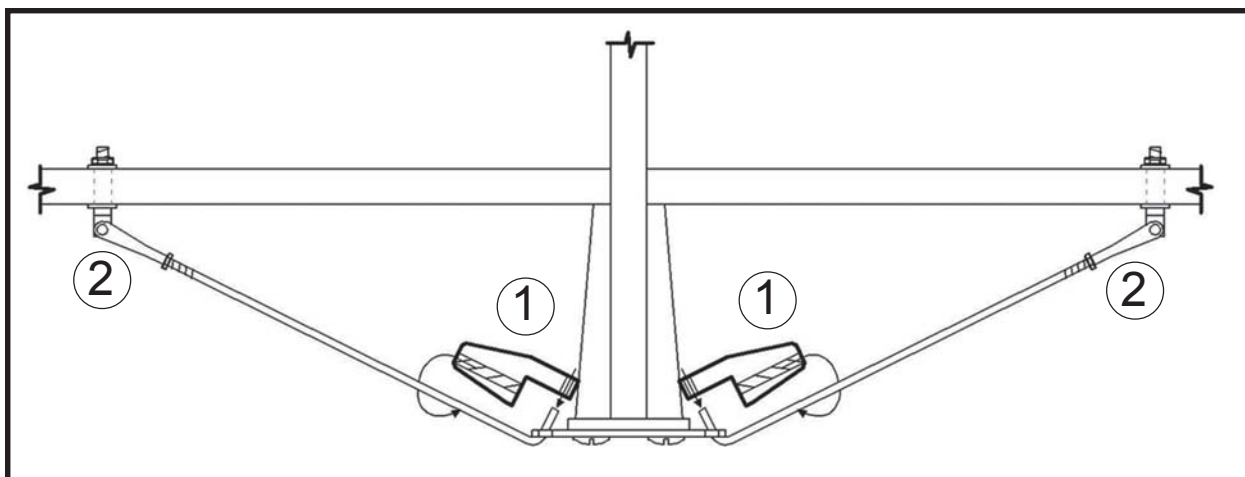

MOUNTING THE TAIL WHEEL.

See pictures below.

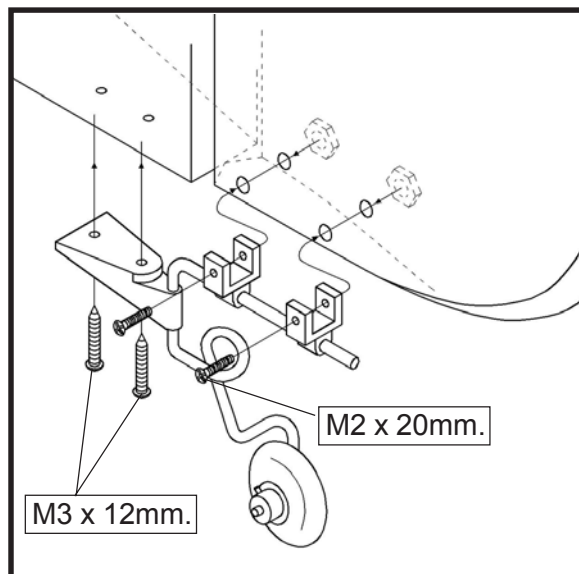

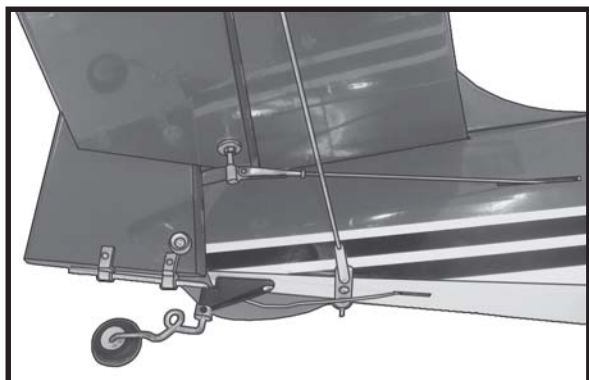

INSTALLING THE BATTERY-RECEIVER.

- 1) Plug the six servo leads and the switch lead into the receiver. Plug the battery pack lead into the switch also.
- 2) Wrap the receiver and battery pack in the protective foam rubber to protect them from vibration.
- 3) Route the antenna in the antenna tube inside the fuselage and secure it to the bottom of fuselage using a plastic tape.

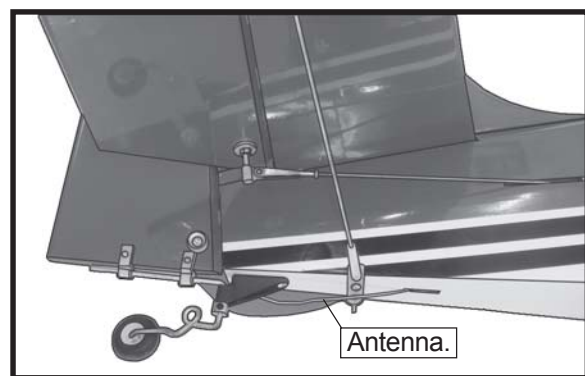
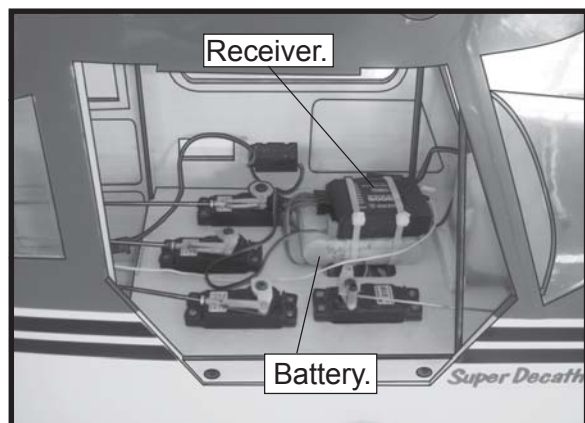

ATTACHMENT WING-FUSELAGE.

Attach the aluminium tube into fuselage.

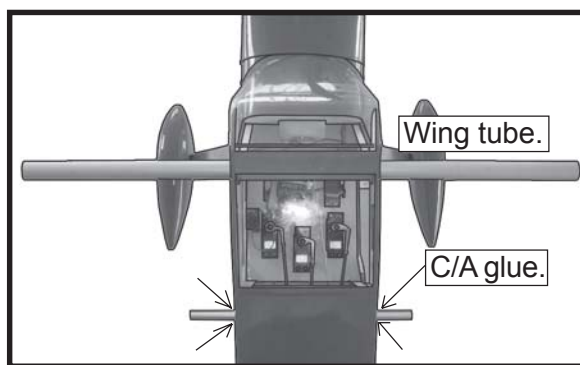
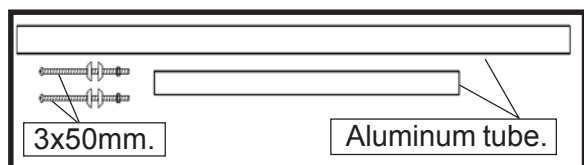

Insert two wing panels as pictures below.

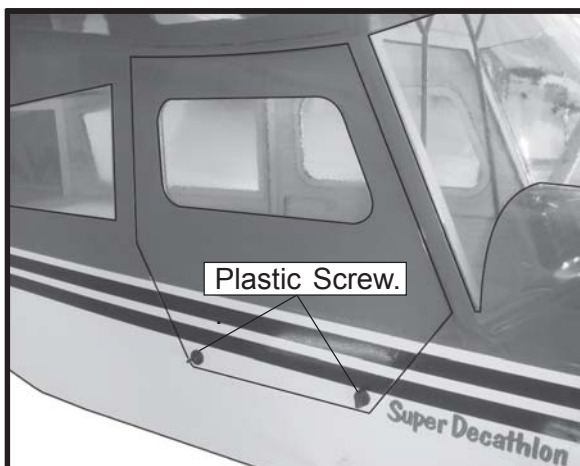
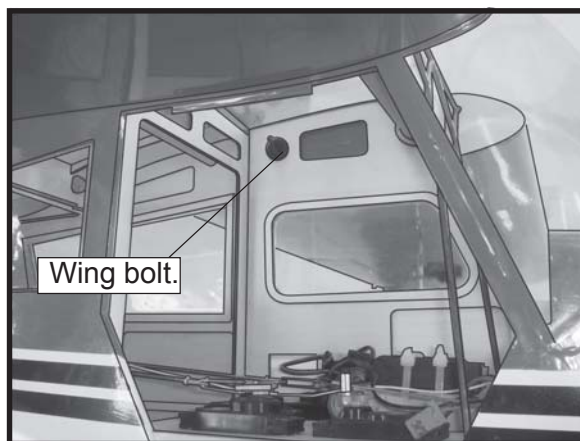
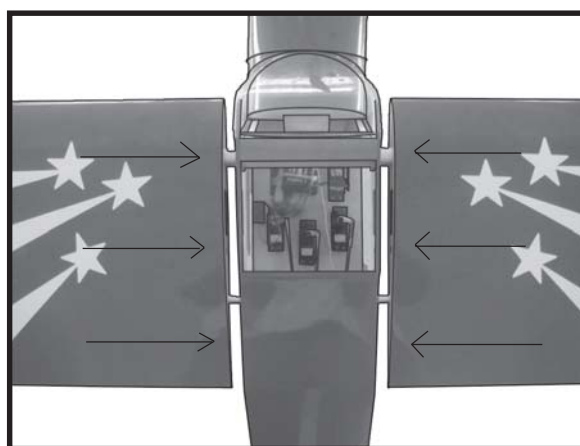

INSTALLING THE WING STRUT .

Parts requirement. See pictures below.

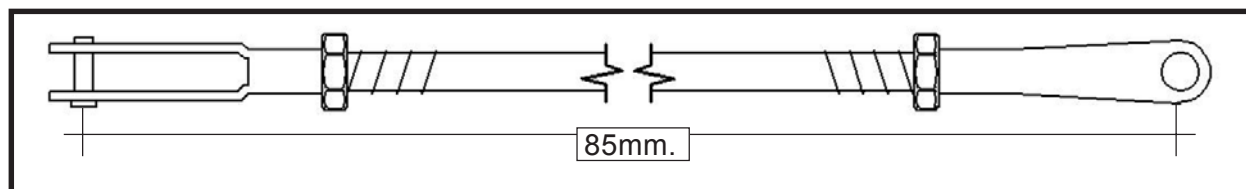
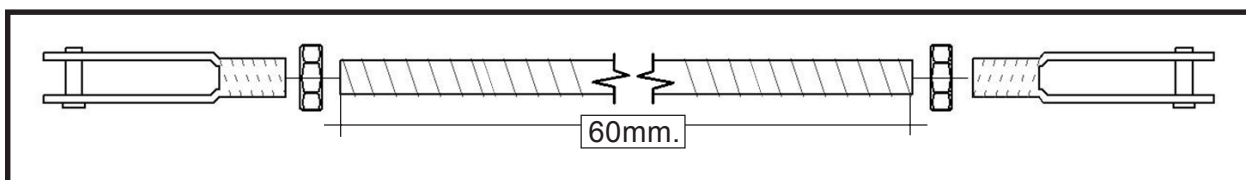
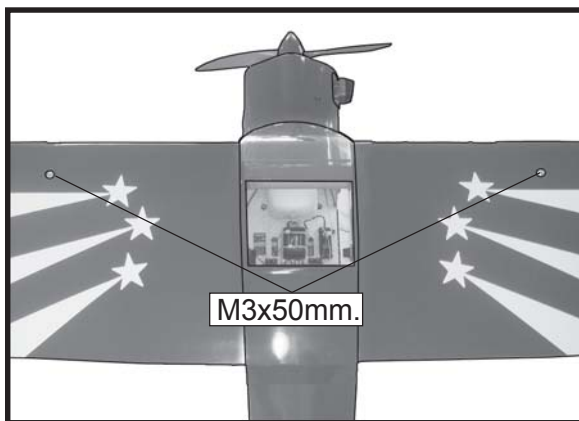
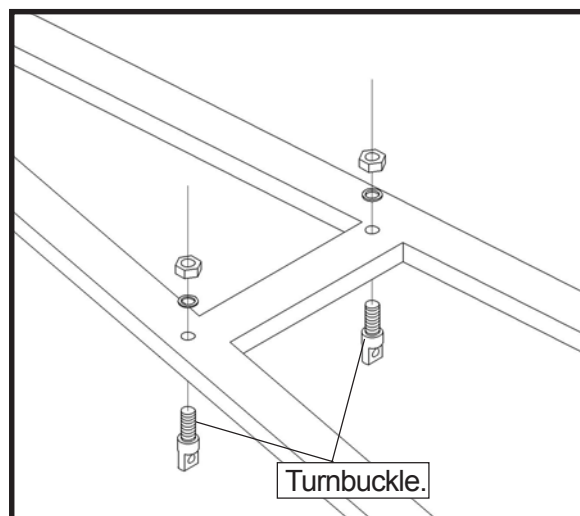
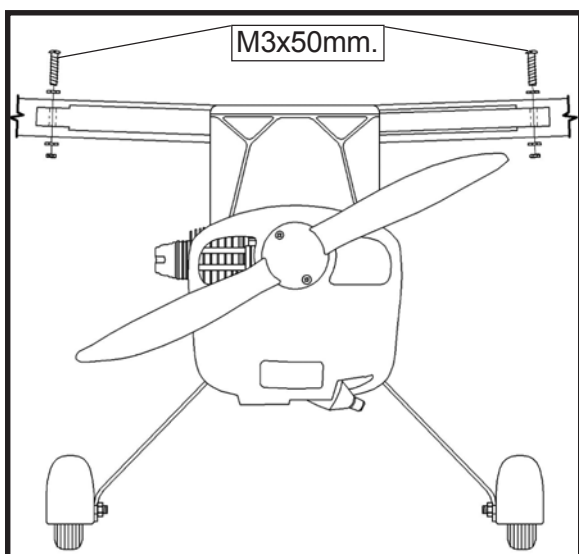
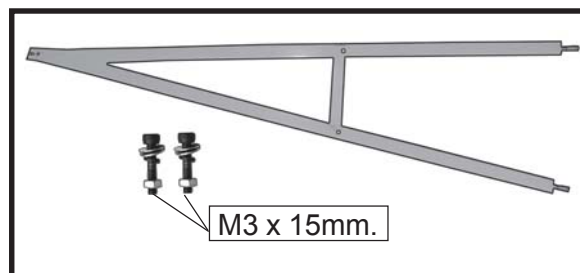
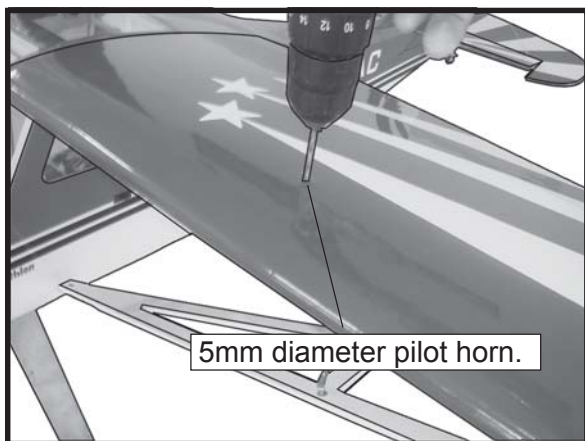

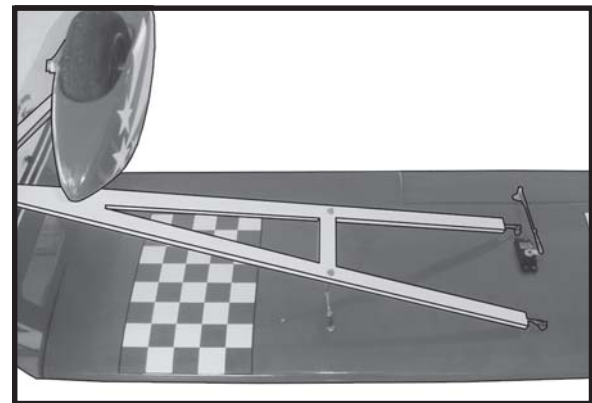
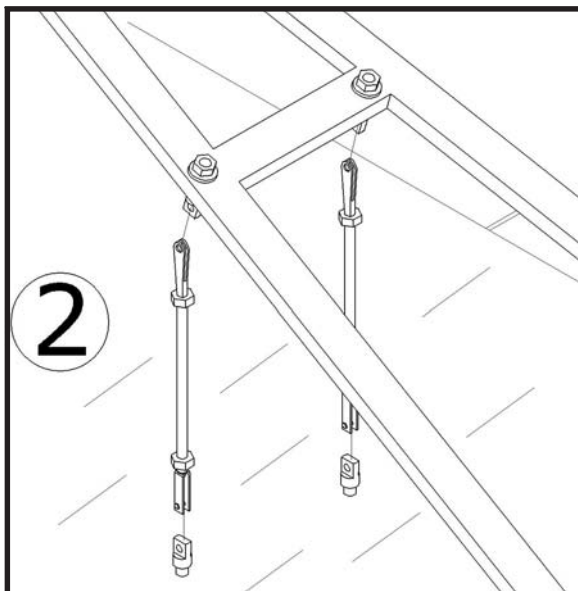
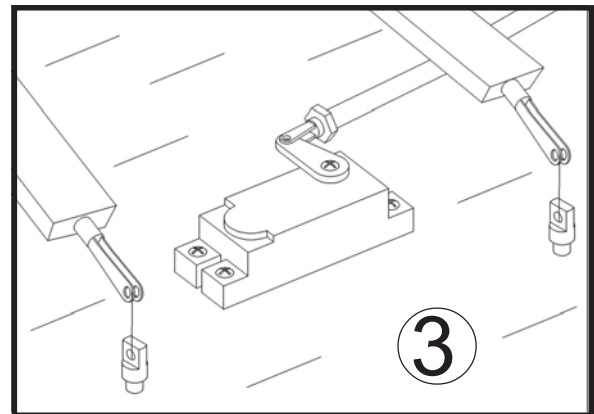
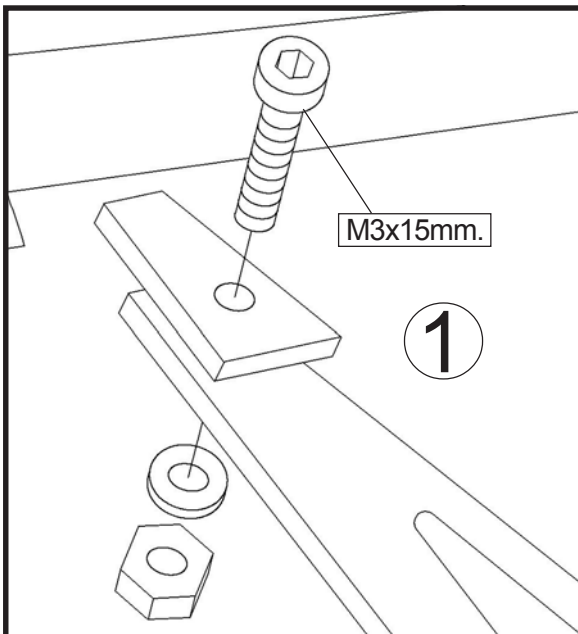
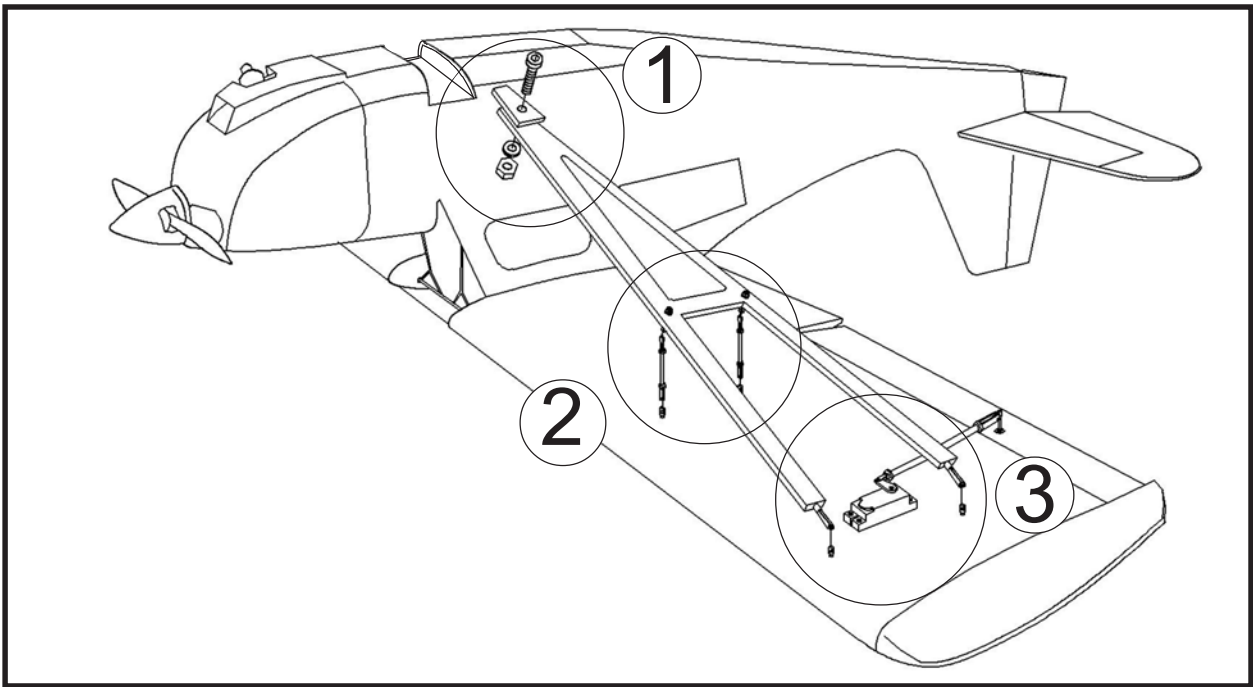

BALANCING.

□1) It is critical that your airplane be balanced correctly. Improper balance will cause your plane to lose control and crash. The center of gravity is locate **8.7cm** back from the leading edge of the wing, measured at wing tip.

□2) If the nose of the plane falls, the plane is nose heavy. To correct this first move the battery pack further back in the fuselage. If this is not possible or does not correct it, stick small amounts of lead weight on the fuselage sides under the horizontal stabilizer. If the tail of the plane falls, the plane is tail heavy.

To correct this, move the battery and receiver forward or if this is not possible, stick weight onto the firewall. When balanced correctly, the airplane should sit level or slightly nose down when you lift it up with your fingers.

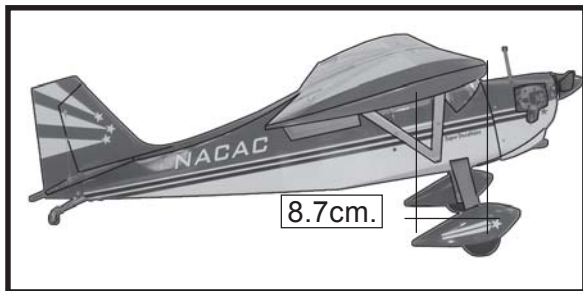

CONTROL THROWS.

□ 1) We highly recommend setting up the **DECATHLON** using the control throws listed at right. We have listed control throws for both Low Rate (initial test flying/sport flying) and High Rate (aerobatic flying).

□ 2) Turn on the radio system, and with the trim tabs on the transmitter in neutral, center the control surfaces by making adjustments to the clevises or adjustable servo connectors. The servo arms should be centered also.

□ 3) When the elevator, rudder and aileron control surfaces are centered, use a ruler and check the amount of the control throw in each surface. **The control throws should be measured at the widest point of each surface!**

□ 4) By moving the position of the adjustable control horn out from the control surface, you will decrease the amount of throw of that control surface. Moving the adjustable control horn toward the control surface will increase the amount of throw.

INITIAL FLYING

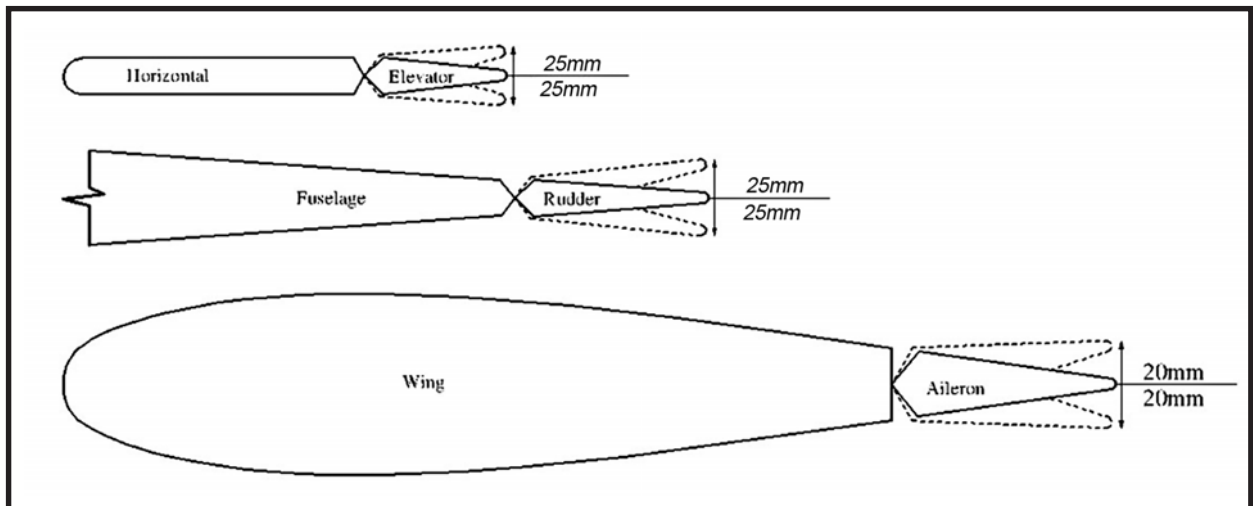

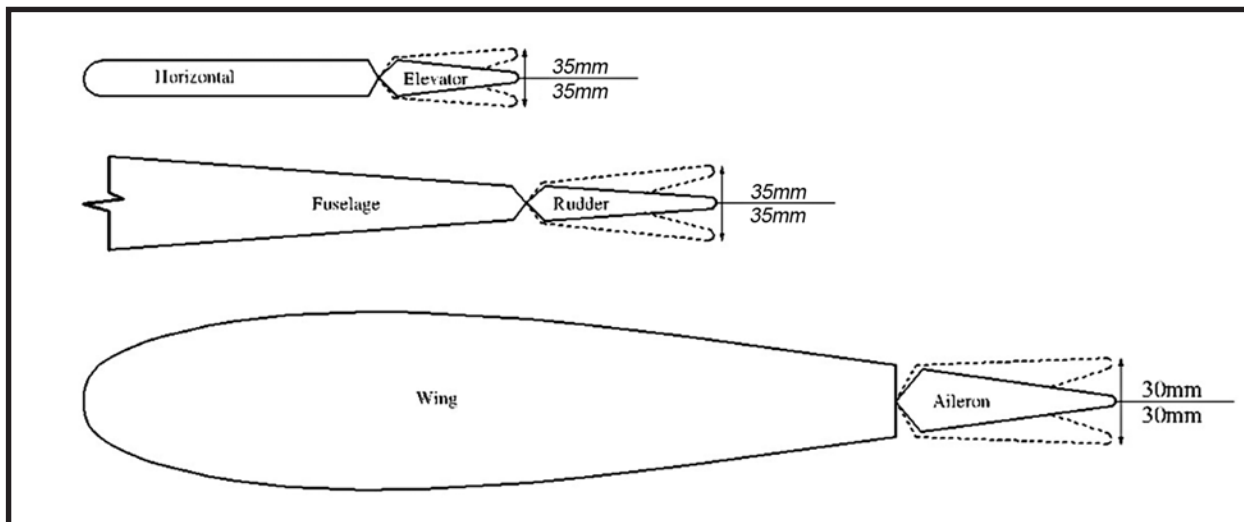
AEROBATIC FLYING**FLIGHT PREPARATION.**

- A) Check the operation and direction of the elevator, rudder, ailerons and throttle.
- B) Plug in your radio system per the manufacturer's instructions and turn everything on.
- C) Check the elevator first. Pull back on the elevator stick. The elevator halves should move up. If it they do not, flip the servo reversing switch on your transmitter to change the direction.
- D) Check the rudder. Looking from behind the airplane, move the rudder stick to the right. The rudder should move to the right. If it does not, flip the servo reversing switch on your transmitter to change the direction.
- E) Check the throttle. Moving the throttle stick forward should open the carburetor barrel. If it does not, flip the servo reversing switch on your transmitter to change the direction.
- F) From behind the airplane, look at the aileron on the right wing half. Move the aileron stick to the right. The right aileron should move up and the other aileron should move down. If it does not, flip the servo reversing switch on your transmitter to change the direction.

PREFLIGHT CHECK.

- 1) Completely charge your transmitter and receiver batteries before your first day of flying.
- 2) Check every bolt and every glue joint in the **DECATHLON** to ensure that everything is tight and well bonded.
- 3) Double check the balance of the airplane. Do this with the fuel tank empty.
- 4) Check the control surfaces. All should move in the correct direction and not bind in any way.
- 5) If your radio transmitter is equipped with dual rate switches double check that they are on the low rate setting for your first few flights.
- 6) Check to ensure the control surfaces are moving the proper amount for both low and high rate settings.
- 7) Check the receiver antenna. It should be fully extended and not coiled up inside the fuselage.
- 8) Properly balance the propeller. An out of balance propeller will cause excessive vibration which could lead to engine and/or airframe failure.

We wish you many safe and enjoyable flights with your DECATHLON .